

LECTURE NOTES

ON

ENGINEERING MECHANICS

**Ganesh Institute of Engineering and
Technology**



**SCTE &VT, BHUBANESWAR
ODISHA**

**1st & 2nd Semester Diploma in Mechanical Engineering
(As per Syllabus prescribed by SCTE&VT, Odisha)**

By

Subject Coordinator: Er. Ranajit Samantaray

LECTURER, MECHANICAL ENGINEERING

MECHANICS

1. FUNDAMENTALS OF ENGINEERING MECHANICS

1.1 Fundamentals

Mechanics is that branch of science which deals with the forces and their effects on bodies on which they act and as a result the body may either be in rest or motion.

Mechanics is divided into two parts.

- (i) **Statics:-** Statics deals with the forces acting on a body under which the body is in rest.
- (ii) **Dynamics:-** Dynamics deals with the forces acting on a body under which it is in motion.

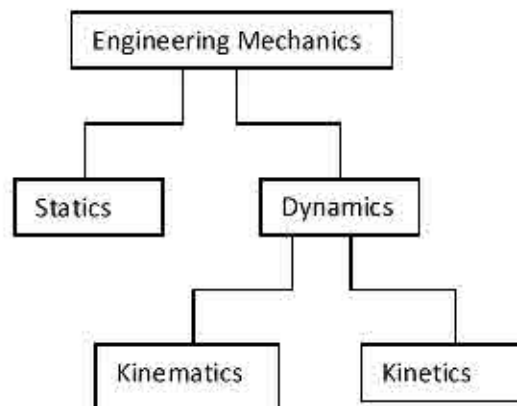

Further the Dynamics is divided into two parts

- (a) **Kinematics:-** Kinematics deals with the motion of bodies in which the agents responsible for motion is not considered.
- (b) **Kinetics:-** Kinetics deals with the motion of the bodies in which the agents responsible for motion is considered. It deals with the relationship between forces and the resulting motion of bodies on which they act.

RIGID BODY

A rigid body is one which does not change its shape and size under the effect of force acting over it. It differs from an elastic body in the sense that the latter undergoes deformation under the effect of forces acting on it and return to its original shape and size on removal of the forces

acting on the body. The rigidity of a body depends upon the fact that how far it undergoes deformation under the effect of forces acting on it.

In real sense no solid body is perfectly rigid because everybody changes its size and shape under the effect of forces acting on it. Actually the deformation in a rigid body is very small and is generally neglected.

DEFINITIONS OF SOME RELATED TERMS

Mass:- The amount of matter contained in a body is called its mass, and for most problems in mechanics, mass may be considered constant.

Weight:- The force with which a body is attracted towards the centre of earth by the gravitational pull (g) is called its weight.

The relation between Mass(M) and Weight(W) of a body is given by the equation $W=M \cdot g$

The value of $g = 9.81 \text{ m/s}^2$.

Length:- This term is applied to the linear dimensions of a straight or curved line. e.g. the diameter of a circle is the length of a straight line which divides the circle into two equal parts; the circumference is the length of its curved perimeter. Length is expressed in meter, cm, Km, feet etc.

Time:- The interval between two events is called time. It is expressed in Second, Minute and Hour.

Scalar:- Any physical quantity which has magnitude only is known as Scalar Quantity. Example:- Mass, distance, Volume, Time density etc.

Vector:- Any physical quantity which has magnitude as well as direction is known as Vector quantity. Example:- Force, Velocity, Displacement, Acceleration, Moment etc.

Fundamental units:- The basic quantities or fundamental quantities of mechanics are those quantities which cannot be expressed in terms of one another. Mass, Length, Time are usually considered as basic or fundamental quantities. The units of these quantities are called fundamental units and are denoted by M, L, T respectively.

Derived units:- The units of all other quantities except the fundamental Quantities are derived with the help of fundamental units and thus they are known as derived units. For Example units of Velocity, acceleration, Density etc are derived units and are as follows.

Velocity(V) = Displacement/Time = $L/T = LT^{-1}$.

Acceleration(a) = Velocity/Time = $LT^{-1}/T = LT^{-2}$.

Density(ρ) = Mass/Volume = $M/L^3 = ML^{-3}$.

SYSTEM OF UNITS:

Generally we use four system of units and they are as follows

1. Foot –Pound-Second(FPS) System:- In this system the units of fundamental quantities i.e Length, Mass and Time are expressed in Foot, Pound and Second respectively.
2. Centimeter- Gram-Second(CGS) System:- In this system the value of Length, Mass and Time are expressed as Centimeter, Gram and Second.
3. Meter-Kilogram-Second(MKS) System:- In this system units of Length, Mass and Time are expressed in Meter, Kilogram and second respectively.
4. International System of units(S I Unit):- This system considers three more fundamental units of Electric Current, Temperature and Luminous intensity in addition to the fundamental units of Mass, Length and Time.

FORCE

Defination of force and its units:-

Force:- Force is something which changes or tends to change the state of rest or of uniform motion of a body in a straight line. Force is the direct or indirect action of one body on another. It is a vector quantity.

There are different kinds of forces such as Gravitational, Frictional, Magnetic, Inertia or those caused by Mass and acceleration.

Units of Force:-

Absolute units:- Because the mass and acceleration are measured differently in different systems of units, so the units of force are also different in the various systems as below

FPS System:- Ft/S^2 .(Poundal)

CGS System:- Cm/S^2 .(Dyne)

MKS or S I System :- M/S^2 .(Newton)

1 Newton = 10^5 Dynes.

Gravitational Units:- These are the units which are used by engineers for all practical purposes, these units depends upon the weight of a body. Now the weight of the body of mass (m) = mg , where g = Acceleration due to gravity.

So the gravitational units of force in the three systems of units i.e, FPS,CGS,and MKS are Pound weight, Gram weight and Kilogram weight.

The relationship of units of force is as follows

1 lb wt. = g Poundal = 32.2 Poundals

1 gm wt. = g Dynes = 981 Dynes

1 Kg wt. = g Netwon = 9.81Newtons.

Gravitational units of force= 'g' times the corresponding absolute units of force.

Representation of Force by Vector:-

Vector Representation:- A force can be represented graphically by a vector as shown in Fig-1 and Fig-2.

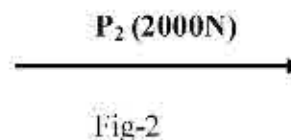
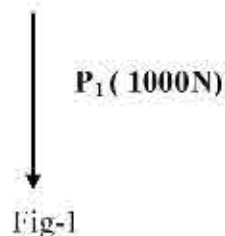

CHARACTERISTICS OF FORCE:-

The characteristics or elements of the Force are the quantities by which a force is fully represented. These are (i) Magnitude(i.e, 500 N, 1000N etc) (ii) Direction or line of action(Angle relative to a coordinate System) (iii) Sense or nature (Push or Pull) (iv) Point of application.

Effects of Force:-

When a force acts on a body, the effects produced in that body may be as follows:-

- (i) It may bring a change in the motion of the body i.e, the motion may be accelerated or retarded.
- (ii) It may balance the forces already acting on the body thus bringing the body to a state of rest or of equilibrium, and

- (iii) It may change the size or shape of the body i.e, the body may be twisted , bend, stretched, compressed or otherwise distorted by the action of the force.

FORCE SYSTEMS

A force system is a collection of forces acting on a body in one or more planes.

According to the relative epositions of the lines of action of the forces, the forces may be classified as follows.

1. Coplanner Concurrent Colinear Force system:

It is the simplest force system and includes those forces whose vectore lie along the same straight line .



Fig-3

2. Coplanner Concurrent Non- Parallel Force System:-

Forces whose lines of action pass through a common point are called Concurrent forces. I

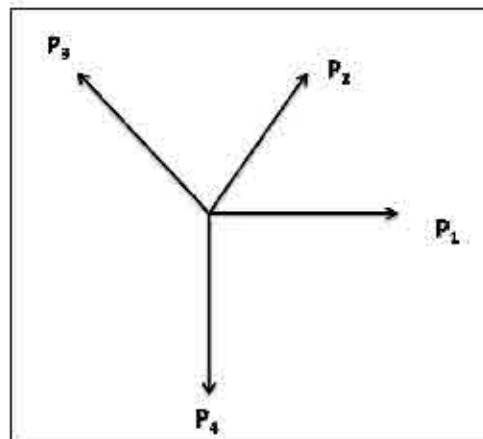

Fig-4

In this system lines of action of all the forces meet at a point but have different directions in the same plane are shown as in the figure.

3. Coplanar Non-Concurrent Parallel Force system.

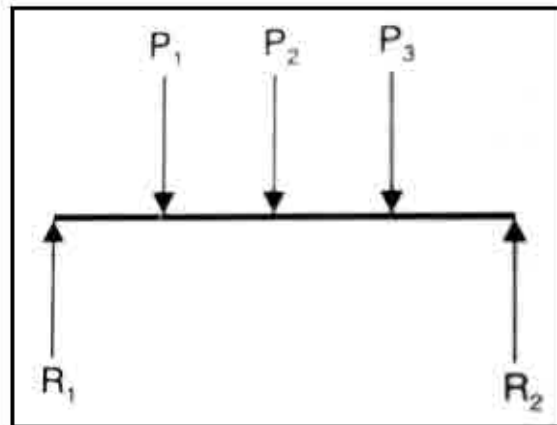

Fig-5

In this system, the lines of action of all the forces lie in the same plane and are parallel to each other but may not have same direction as shown in the figure.

4. Coplanar Non-Concurrent Non-Parallel Force system:-

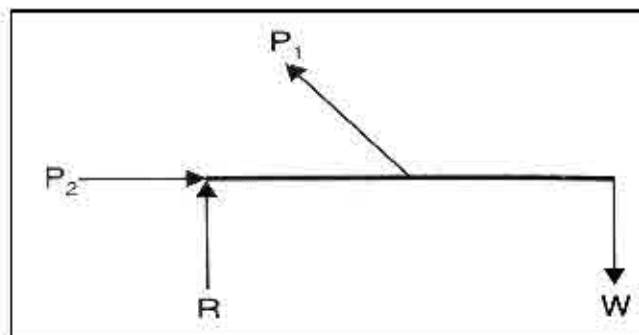

Fig-6

Such a system exists where the lines of action of all forces lie in the same plane but do not pass through a common point as shown in the figure.

5. Non- Coplaner Concurrent Force System:-

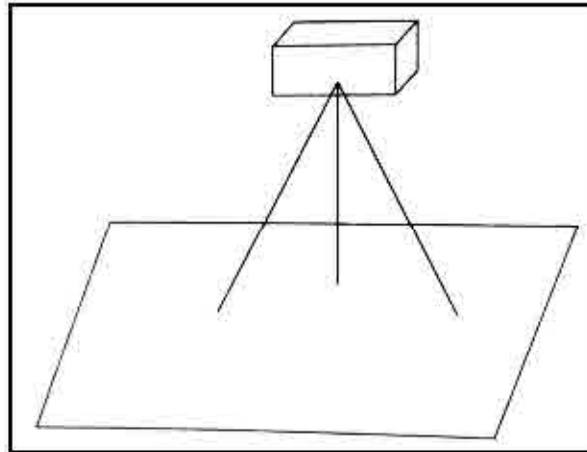

Fig-7

This system is evident where the lines of action of all forces do not lie in the same plane but do pass through a common point. An example of this force system is the forces in the legs of tripod support of a dumpy level.

6. Non- Coplaner Non- Concurrent Force system:-

Where the lines of action of all forces do not lie in the same plane and do not pass through a common point, a Non- Coplaner Non- Concurrent system is present.

Principle of transmissibility:-The Principle of Transmissibility of force states that when a force acts upon a body, its effect is the same whatever point in its line of action is taken as the point of application provided that the point is connected with the rest of the body in the same invariable manner.

Laws of Superposition:-

The action of a given system of force on a rigid body will in no way be changed if we add or subtract from them another system of forces in equilibrium.

Action & Reaction Forces:- Whenever there are two bodies in contact, each exerts a force on other. Out of these force one is called action and the other is called reaction. Action and reaction are equal and opposite.

FREE BODY DIAGRAM:-

A body may consist of more than one element and supports. Each element or support can be isolated from the rest of the system by incorporating the net effect of the remaining system through a set of forces. A free body diagram is a process of isolating a body from all of its supports and in the place of the support a force of required magnitude is provided so that the position of the body will not change.

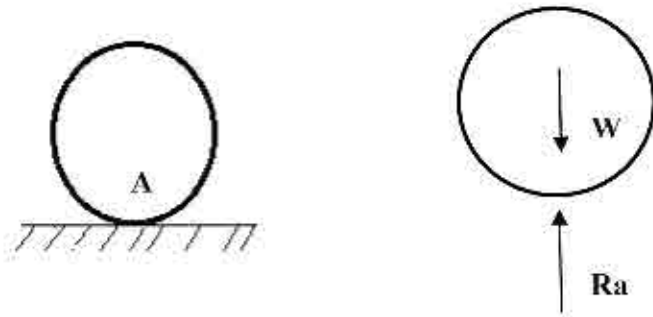

Fig-a

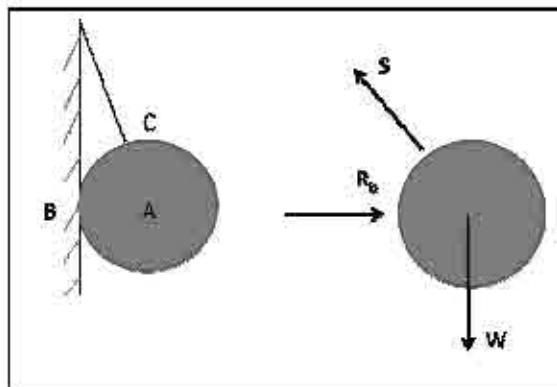

Fig-b

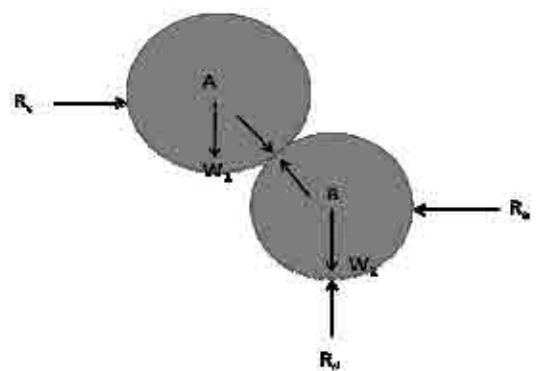
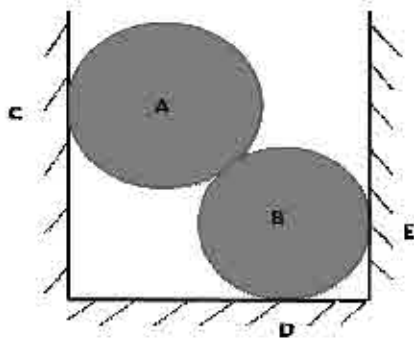

Fig-c

Theorem of Varignon:-

The moment of the resultant of two concurrent forces with respect to a center in their plane is equal to the algebraic sum of the moments of the components with respect to the same center.

Proof:-

Let us consider two forces 'P' and 'Q' with respect to the center 'O'.

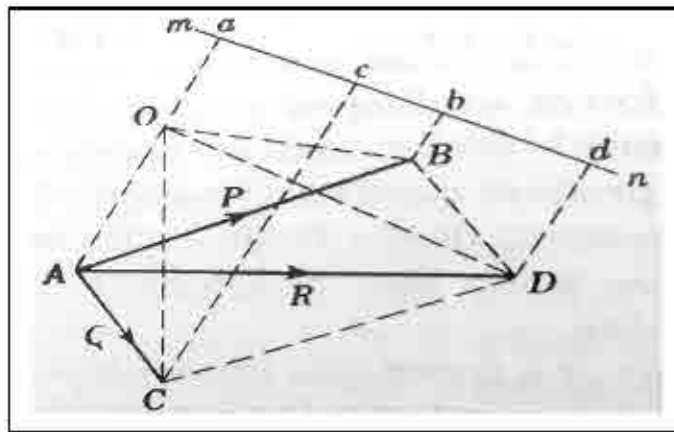

In the plane of action of forces, we take any line mn perpendicular to the line OA joining the moment center with the point of concurrence of the forces and construct the perpendiculars Aa, Bb, Cc and Dd , as shown in figure.

Now the area of $\triangle OAB = \frac{1}{2} OA \cdot ab$, the area of $\triangle OAC = \frac{1}{2} OA \cdot ac$, and the area of $\triangle OAD = \frac{1}{2} OA \cdot ad$.

Since $ad = ab + bd = ab + ac$

We conclude that $\text{Area } \triangle OAD = \text{area } \triangle OAB + \text{area } \triangle OAC$,

This proves the theorem.

1.3 RESOLUTION OF A FORCE

As two forces acting simultaneously on a particle acting along directions inclined to each other can be replaced by a single force which produces the same effect as that of the given force similarly a single force can be replaced by two forces acting in directions which will produce the same effect as that of the given force.

This breaking up of a force into two parts is called the resolution of a force.

RESULTANT OF A FORCE

A resultant force is a single force which can replace two or more forces and produce the same effect on the body as that of the forces.

COMPONENT OF A FORCE

Generally a force is resolved into the following two types of components.

1. Mutually perpendicular components.
2. Non- Perpendicular components.

1. Mutually Perpendicular Components:-

Let us consider a force 'P' which is to be resolved is represented in both magnitude and direction by 'oc' in the figure below.

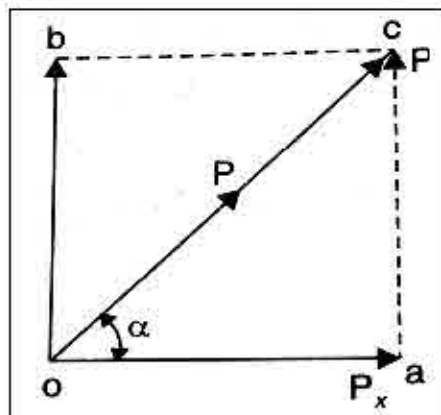

Let P_x is the component of force P in the direction oa making an angle ' α ' with the direction oc.

Complete the rectangle *oacb*.

The other component P_y at right angle to P_x will be represented by 'ob' which is also equal to ac.

Now from the right angled triangle *oac*.

$$P_x = oa = P \cos \alpha \quad \text{and} \quad P_y = P \sin \alpha.$$

2. Non- Perpendicular Component.

Referring figure below Let oc represents the given force P in magnitude and direction to some scale.

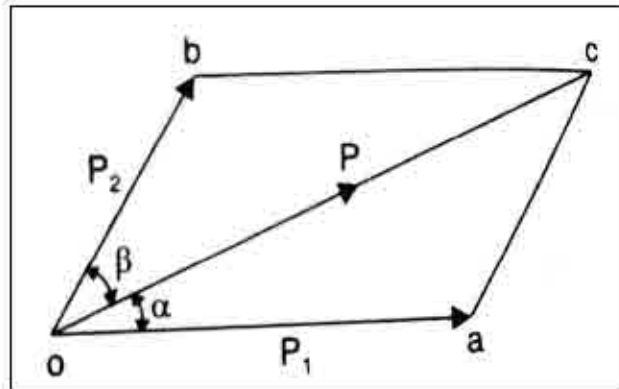

Draw oa and ob making angle ' α ' and ' β ' with oc .

Through c draw ca parallel to ' ob ' and ' cb ' parallel to ' oa ' to complete the parallelogram ' $oacb$ '.

Now the vectors oa and ob represent in magnitude and direction as P_1 and P_2 respectively.

Now from the triangle ' oac ', by applying sine rule

$$\frac{oa}{\sin\beta} = \frac{oc}{\sin[180-(\alpha+\beta)]} = \frac{oc}{\sin\alpha}$$

$$\text{or } \frac{P_1}{\sin\beta} = \frac{P}{\sin(\alpha+\beta)} = \frac{P_2}{\sin\alpha}$$

$$\text{so } P_1 = P \cdot \frac{\sin\beta}{\sin(\alpha+\beta)} \quad \text{and} \quad P_2 = P \cdot \frac{\sin\alpha}{\sin(\alpha+\beta)}$$

RESULTANT OF SEVERAL COPLANNER CONCURRENT FORCES:-

For the resultant of a number of concurrent forces any of the following two methods are used.

1. Graphical Method

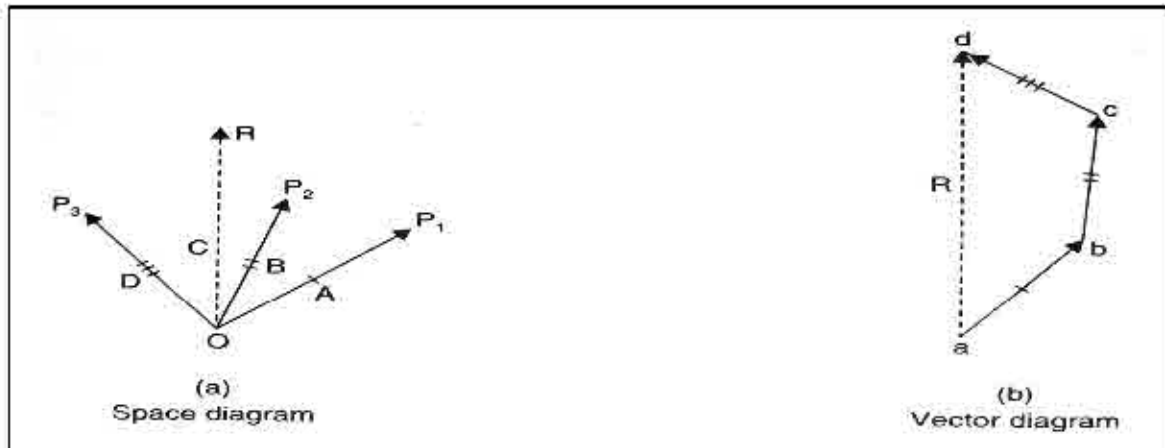

2. Analytical Method

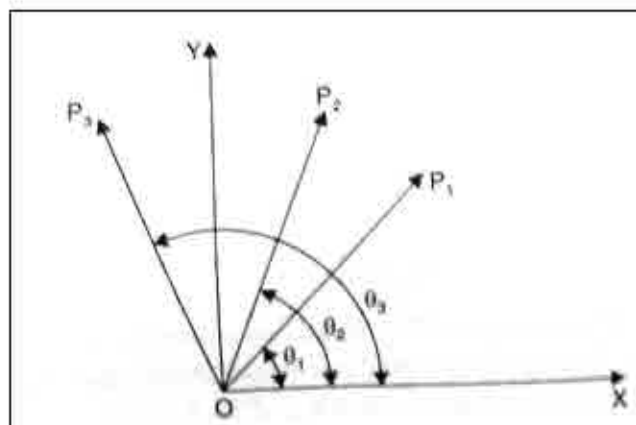

And the resolution of P_3 in the direction OX is $P_3 \cos\theta_3$, and in the direction OY is $P_3 \sin\theta_3$.

If the resultant R makes an angle θ with OX, then as per resolution,

$$R \cos\theta = P_1 \cos\theta_1 + P_2 \cos\theta_2 + P_3 \cos\theta_3 = \sum H$$

$$\text{And } R \sin\theta = P_1 \sin\theta_1 + P_2 \sin\theta_2 + P_3 \sin\theta_3 = \sum V$$

$$\text{Now Resultant } R = \sqrt{(\sum H^2) + (\sum V^2)}$$

$$\text{Now } \frac{R \sin\theta}{R \cos\theta} = \frac{\sum V}{\sum H}$$

$$\text{So } \theta = \tan^{-1} \left(\frac{\sum V}{\sum H} \right)$$

Sign Convention for resolution:-

The upward forces (\uparrow) is considered - Positive (+)

The downward forces (\downarrow) is considered - Negative (-)

The Right Hand Side forces is - Positive (+)

The left Handed forces is - Negative (-)

Example -1

The following forces act a point:

- (i). 20N inclined at 30° towards north of east.
- (ii). 25N towards north
- (iii). 30N towards north west and
- (iv). 35N inclined at 40° towards south of west.

Find the magnitude and direction of the resultant force.

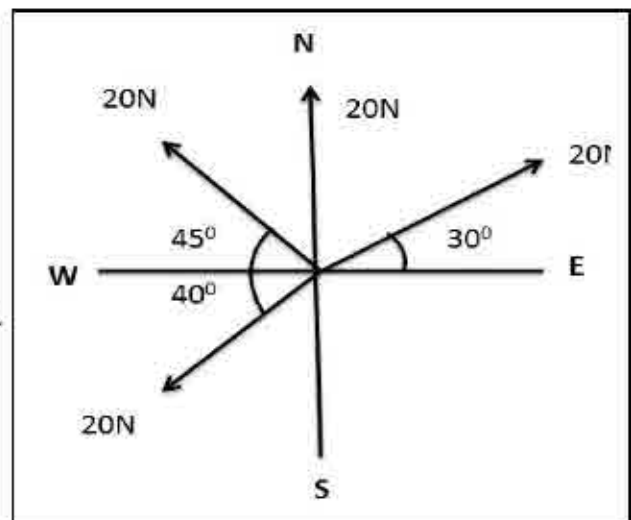

Answer:-

Magnitude of the resultant force

Resolving all the forces horizontally i.e. along East-west line,

$$\begin{aligned}EH &= 20 \cos 30^\circ + 20 \cos 90^\circ + 30 \cos 135^\circ + 35 \cos 220^\circ \text{ N} \\ &= (20 \times 0.866) + (25 \times 0) + 30(-0.707) + 35(-0.766) \text{ N} \\ &= -30.7 \text{ N}\end{aligned}$$

And now resolving all the forces vertically i.e. along north-south line,

$$\begin{aligned}EV &= 20 \sin 30^\circ + 25 \sin 30^\circ + 30 \sin 135^\circ + 35 \sin 220^\circ \text{ N} \\ &= (20 \times 0.5) + (25 \times 1.00) + (30 \times 0.707) + 35(-0.6428) \text{ N} \\ &= 33.7 \text{ N}\end{aligned}$$

We know that the magnitude of the resultant force,

$$\begin{aligned}R &= \sqrt{(\sum H)^2 + (\sum V)^2} = \sqrt{(-30.7)^2 + (33.7)^2} \text{ N} \\ &= 45.6 \text{ N} \quad \dots\dots\dots (\text{Ans.})\end{aligned}$$

Direction of the resultant force

Let θ = Angle, Which the resultant force makes with the East.

$$\text{Thus, } \tan \theta = \frac{\sum V}{\sum H} = \frac{33.7}{-30.7} = -1.098 \text{ or } \theta = 47^\circ 42'$$

Since $\sum H$ is -Ve and $\sum V$ is +Ve, therefore θ lies between 90° and 180° .

$$\text{Thus, Actual } \theta = 180^\circ - 47^\circ 42' = 132^\circ 18' \quad \dots\dots\dots (\text{Ans.})$$

Example-2

Determine the magnitude and direction of the resultant of the two forces of magnitude 12 N and 9 N acting at a point, if the angle between the two forces is 30° .

Given:-

$$F_1 = 12N \quad F_2 = 9N \quad \alpha = 30^\circ$$

$$\begin{aligned} R &= \sqrt{F_1^2 + F_2^2 + 2F_1F_2 \cos \alpha} \\ R &= \sqrt{12^2 + 9^2 + 2 \times 12 \times 9 \times \cos 30^\circ} \\ R &= 20.3N \\ \theta &= \tan^{-1} \left(\frac{F_2 \sin \alpha}{F_1 + F_2 \cos \alpha} \right) \\ \theta &= \tan^{-1} \left(\frac{9 \sin 30^\circ}{12 + 9 \cos 30^\circ} \right) \\ \theta &= 12.81^\circ \end{aligned}$$

Example-3

2. Find the magnitude of two equal forces acting at a point with an angle of 60° between them, if the resultant is equal to $30\sqrt{3}N$
GIVEN:

$$\begin{aligned} F_1 &= F_2 = F, \text{ say} \\ R &= 30\sqrt{3}N, \alpha = 60^\circ \\ R &= \sqrt{F_1^2 + F_2^2 + 2F_1F_2 \cos \alpha} \\ R &= \sqrt{F^2 + F^2 + 2F \times F \times \cos 60^\circ} \\ R &= \sqrt{F^2 + F^2 + F^2} \\ R &= \sqrt{3}F \\ F &= 30N \end{aligned}$$

Example-4

Two forces of magnitudes $3P$ and $2P$ respectively acting at a point have a resultant R . If the first force is doubled, the magnitude of the resultant is doubled. Find the angle between the two forces ($3P$ and $2P$).

Ans:- Let θ = angle between two forces $3P$ and $2P$.

$$\begin{aligned} \text{We Know that } R^2 &= (3P)^2 + (2P)^2 + 2(3P)(2P)\cos\theta \\ &= 9P^2 + 4P^2 + 12P^2\cos\theta \\ &= 13P^2 + 12P^2\cos\theta \quad \dots\dots\dots(i) \end{aligned}$$

Now doubling the first force and the resultant both, we have

$$\begin{aligned} (2R)^2 &= (6P)^2 + (2P)^2 + 2(6P)(2P)\cos\theta \\ \Rightarrow 4R^2 &= 36P^2 + 4P^2 + 24P^2\cos\theta = 40P^2 + 24P^2\cos\theta \quad \dots\dots\dots(ii) \end{aligned}$$

Substituting the value of R^2 from eqn (i) in eqn (ii), we get

$$\begin{aligned} 4(13P^2 + 12P^2\cos\theta) &= 40P^2 + 24P^2\cos\theta & \Rightarrow 52P^2 + 48P^2\cos\theta &= 40P^2 + 24P^2\cos\theta \\ \Rightarrow 12P^2 &= -24P^2\cos\theta & \Rightarrow \cos\theta &= -1/2. \end{aligned}$$

Hence $\theta = \cos^{-1}(-1/2) = 120^\circ$. (Ans)

1.4 MOMENT OF FORCE

The moment of a force about a point is the product of the force and the perpendicular distance from the point of rotation. A moment is a measure of rotation about a point. A moment has both magnitude and direction.

GEOMETRICAL REPRESENTATION OF MOMENT

Consider a force F represented, in magnitude and direction by the line AB . Let O be a point about which the moment of the force F is required. Let OC be the perpendicular drawn. Join OA and OB

Moment of force F about $O = F \times a$

$= AB \times OC$

$=$ twice the area of triangle OAB

Thus moment of F about $O = 2 \times$ Area of triangle OAB

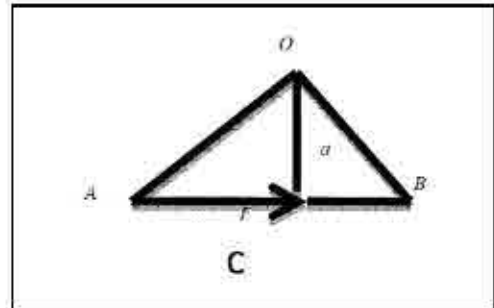

1. Moment Theory

The moment of a force about a point is a measure of the tendency of that force to rotate about that point.

For example, the moment of force F about point “ O ” in Figure 1(a) is a measure of the tendency of the force to rotate the body about line $A-A$. Line $A-A$ is perpendicular to the

plane containing force F and point “ O ”.

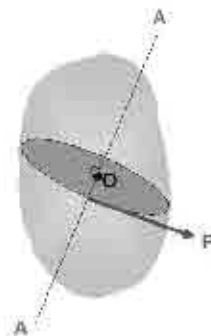

figure 1(a)

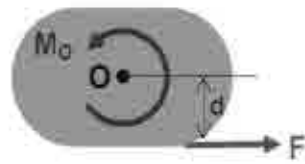

Figure 1(b)

Figure 1(b) shows the plane containing F and "O". Point "O" is called the moment centre, distance "d" is called the moment arm and line A-A is called the axis of the moment.

2. Moment Formula

The moment of a force is the product of that force by its perpendicular distance from the point of rotation.

Moment = Force \times \perp Distance

$$M = F \times \perp d$$

Note: The sum of moments about a point is equal to zero.

$$\sum M_o = 0$$

3. The Unit Of A Moment

The measurement unit of a moment is the Newton metre (Nm).

4. Moment sign convention

When dealing with moments it is important to apply a CONSISTENT sign convention with the direction of the moment.

Look at which way the moment is turning. Is it turning CLOCKWISE or ANTICLOCKWISE?

For the purposes of this activity, let us apply a sign convention:

If a moment is moving ANTICLOCKWISE it is considered a POSITIVE moment.



If a moment is moving **CLOCKWISE** it is considered a **NEGATIVE** moment.



An easy way to remember this sign convention is by using your **RIGHT HAND** as a guide.

For a **POSITIVE** moment turning in an **ANTICLOCKWISE** direction:

Position your hand as shown in **Picture 1**.

Following the arrow with your fingertips and imagine that you are turning a doorknob in an **ANTICLOCKWISE** direction.

You will notice that your hand is turning in the direction where you have more fingers.

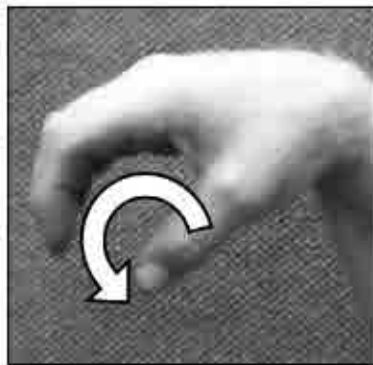

Picture 1

For a **NEGATIVE** moment turning in a **CLOCKWISE** direction, the same thinking applies:

Turn the doorknob in the opposite direction (i.e. the **CLOCKWISE** direction).

- Using your thumb as the guide, turn your hand to follow the arrow as shown in **picture2**.



Picture 2

- Once again you should notice that you are turning your hand in the direction that has LESS fingers, that is, the NEGATIVE direction.

Also you can adopt the opposite sign convention but you have maintain it throughout the problem.

COUPLE:-

A couple is pair of two equal and opposite forces acting on a body in such a way that the line of action of the two forces are not in the same straight line.

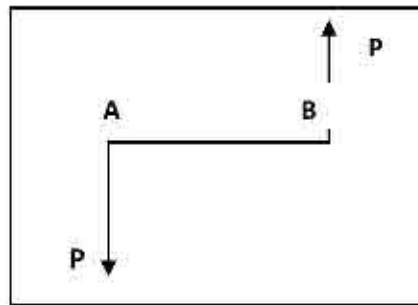

The effect of couple acting on a rigid body is to rotate it without moving it as a whole.

The perpendicular distance between the line of action of two forces forming the couple is known as *arm of couple*.

The moment of a couple is known as torque which is equal to one of the forces forming the couple multiplied by arm of couple.

The following are the example of the couples in everyday life.

1. Opening or closing a water tap. The two forces constitute a couple as shown in Fig. 3.13.
2. Turning of the cap of a pen.
3. Unscrewing the cap of a Ink bottle.
4. Twisting of a screw driver.
5. Steering a motor-cap (Fig. 3.14)
6. Winding a watch or clock with a key.

PROPERTIES OF A COUPLE:-

1. The algebraic sum of the moments of the forces forming a couple about any point in their plane is constant.

Let two parallel and unlike forces be of magnitude P is forming a couple $P \times AB$, where points A and B are the points where forces P and P act.

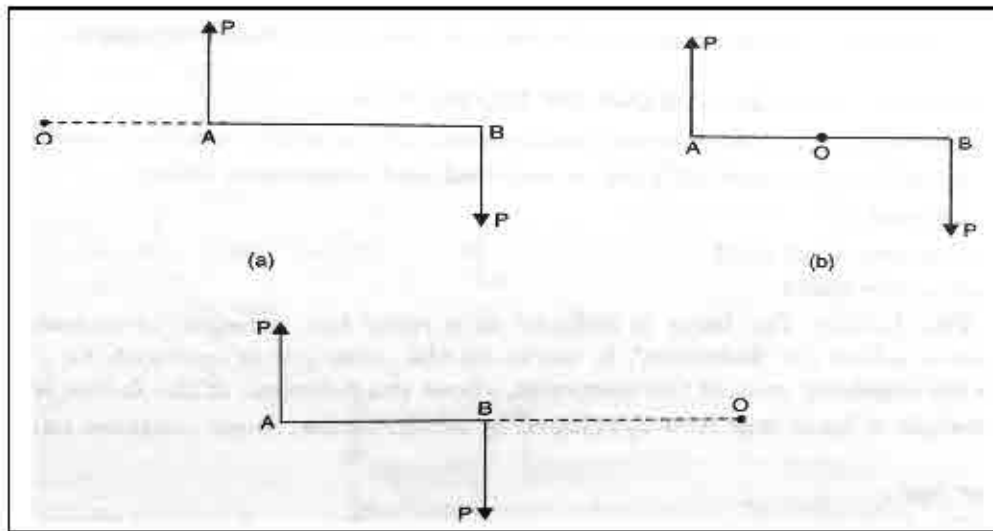

From Fig-(a)- Moments about O = $P \times OB - P \times OA = P(OB - OA) = P \times AB$

From Fig-(b)- Moments about O = $P \times OB + P \times OA = P(OB + OA) = P \times AB$

From Fig-(c)- Moments about O = $P \times OA - P \times OB = P(OA - OB) = P \times AB$

In all the three cases, we found that the sum of the moments in each case is independent of the position of the point O, and depends only on the constant arm of the couple, so the algebraic sum of the moments of the forces forming a couple about any point in their plane is constant.

2. Any two couples of equal moments and sense in the same plane are equivalent in their effect.
3. Two couples acting in one place upon a rigid body whose moments are equal but opposite in sense, balance each other.
4. A force acting on a rigid body can be replaced by an equal like force acting at any other point and a couple whose moments equals the moment of the force about the point where the equal like force is acting.
5. Any number of coplanar couples are equivalent to a single couple whose moment is equal to the algebraic sum of the moments of the individual couples.

Example-1

Determine the sum of moments of the three forces about (a) Point A, (b) Point B and(c) Point C.

Answer:-

(a) The sum of the moments about A:

$$\sum M_A = - (2) (100) + (4) (200) - 6 (100) = 0$$

(b) The sum of the moments about B:

$$\sum M_B = (2) (100) - (2) (100) = 0$$

(c) The sum of the moments about C:

$$\sum M_C = (6) (100) - (4) (200) + (2) (100) = 0$$

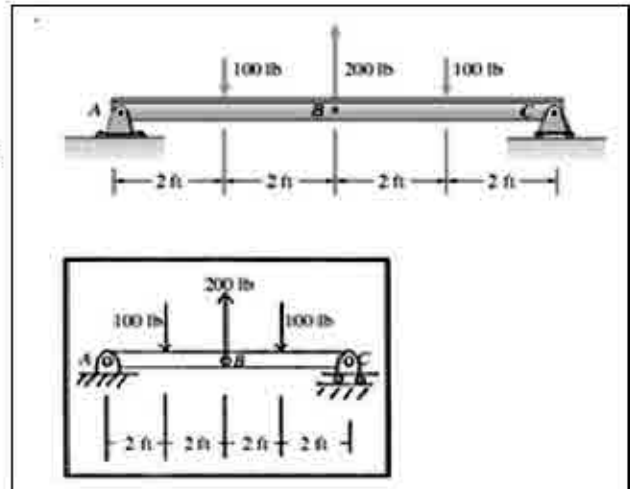

Example:-1

A Man and boy carry a weight of 300 N between them by means of a uniform pole 2m long and weighing 100N. Where must the weight be placed so that the man may bear twice as much of the weight as that of the boy.

As per the fig the weight of the pole acts at the centre G.

Let the boy bears the load W and the Man bears the load 2W.

Let the weight 300N acts at a distance x meters from the man i.e from the point B.

$$\text{Now } \sum V = 0$$

$$\Rightarrow W + 2W = 100 + 300 = 400$$

$$\Rightarrow 3W = 400$$

$$\text{So } W = 400/3 = 133.33 \text{ N}$$

Now taking moment at A (Boy's position)

$$2W \times 2 = 300(2 - x) + 100 \times 1$$

$$\Rightarrow 4W = 600 - 300x + 100 = 700 - 300x$$

$$\Rightarrow 4 \times 133.33 = 700 - 300x$$

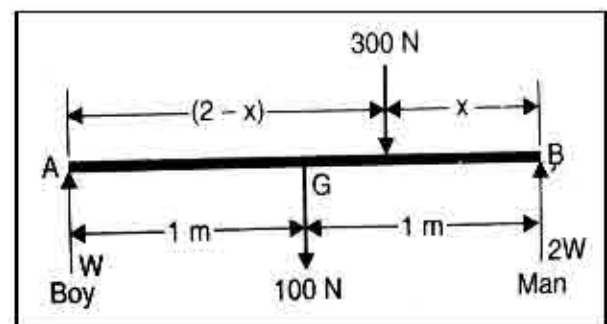

$$\Rightarrow 300x = 166.8$$

$$x = 0.556\text{m}$$

Hence the weight will be placed 0.556 m from the position of man (point B) towards the boy (point A).

Example:-2

A rod of length 5m and weight 15N has its centre of gravity at a distance of 2m from A. It rests on two parallel smooth pegs at a distance 3m apart in the same horizontal plane so that equal portion of the rod project beyond the pegs. Find the reaction at the pegs.

Solution.

Refer to Fig. 3.26. Let G be the c.g of the rod AB, C and D be the pegs. R and S be the reactions at the pegs C and D respectively.

Now $R+S = 15$

$$S = 15 - R \quad \dots\dots\dots (i)$$

Let $AC = x, DB = x$

Taking moments about C, We get

$$15 \times CG = S \times 3$$

$$15(2 - x) = S \times 3$$

$$10 - 5x = S$$

$$10 - 5x = 15 - R \quad \dots\dots \text{From Eqns. (i)}$$

$$R - 5x = 5 \quad \dots\dots\dots (ii)$$

Taking moments about D, We get

$$R \times CD = 15 \times GD$$

$$R \times 3 = 15 \times (3 - x)$$

$$R = 5(3 - x) = 15 - 5x \quad \dots\dots\dots (iii)$$

On solving eqns. (ii) and (iii), we get

$$X = 1 \text{ m}, R = 10 \text{ N}, S = 5 \text{ N.} \quad (\text{Ans})$$

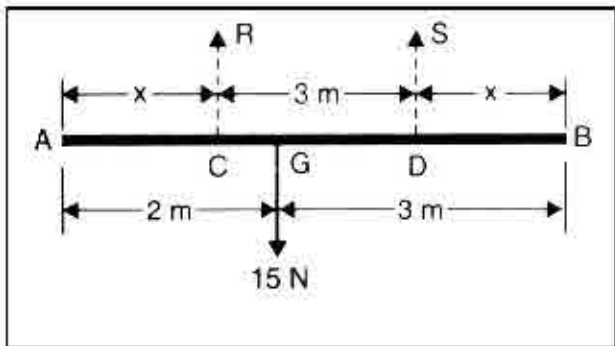

1.5 FORCE SYSTEM

Force:- Force is something which changes or tends to change the state of rest or of uniform motion of a body in a straight line. Force is the direct or indirect action of one body on another. It is a vector quantity.

Classification of force system:-

The classification of force system are as below.

1. According to the effect produced by a force:

- (i) **External Force:-** When a force is applied external to a body is called External force.
- (ii) **Internal Force:-** The resistance to deformation, or change of shape exerted by the material of a body is called an internal force.
- (iii) **Active Force:-** An active force is one which causes a body to move or change its shape.
- (iv) **Passive Force:-** A force which prevents the motion, deformation of a body is called passive force.

2. According to the nature of the forces.

- (i) **Action and reaction:-** Whenever there are two bodies in contact, each exerts a force on other. Out of these force one is called action and the other is called reaction. Action and reaction are equal and opposite.
- (ii) **Attraction and repulsion:-** These are actually non contacting forces exerted by one body or another without any visible medium transmission such as magnetic forces.
- (iii) **Tension and Thrust.-** When a body is dragged with a string the force communicated to the body by the string is called the tension while, if we push the body with a rod the force exerted on the body is called a thrust.

3. According to whether the force acts at a point or is distributed over a large area.

- (i) **Concentrated force.-** The force whose point of application is so small that it may be considered as a point is called a Concentrated force.
- (ii) **Distributed force-** a distributed force is one whose place of application is area.

4. According to whether the force acts at a distance or by contact:-

- (i) **Non contacting forces or forces at a distance:-** Magnetic, Electrical and gravitational forces are examples of the Non contacting forces or forces at a distance.
- (ii) **contacting forces or forces by contact** – The pressure of steam in a cylinder and that of the wheels of a locomotive on the supporting rails are the examples of contacting forces.

LAWS OF FORCES.

The method of determination of the resultant of some forces acting simultaneously on a particle is called composition of forces.

The various laws used for the composition of forces are as follows.

1. Parallelogram law of forces
2. Triangle law of forces
3. Polygon law of forces.

Law of Parallelogram of Forces:-

It states that:

“If two forces, acting simultaneously on a particle, be represented in magnitude and direction by the adjacent sides of a parallelogram then their resultant may be represented in magnitude and direction by the diagonal of the parallelogram which passes through their point of intersection.”

According to figure let two forces P and Q acting simultaneously on a particle be represented in magnitude and direction by the adjacent sides *oa* and *ob* of a parallelogram *oacb* drawn from a point *o*, their resultant R will be represented in magnitude and direction by the diagonal *oc* of the parallelogram.

The value of R can be determined by either Graphically or analytically as explained below.

Graphical Method:-

Draw vectors ‘*oa*’ and ‘*ob*’ to represent two some convenient scale to the forces P and Q in magnitude and direction. Complete the parallelogram ‘*oacb*’ by drawing ‘*ac*’ parallel to ‘*ob*’ and *bc* parallel to *oa*. The vector *oc* measured to the same scale will represent the resultant force R.

Analytical Method:-

As shown in the figure, in the parallelogram oacb from c drop a perpendicular 'cd' to 'oa' at 'd' when produced.

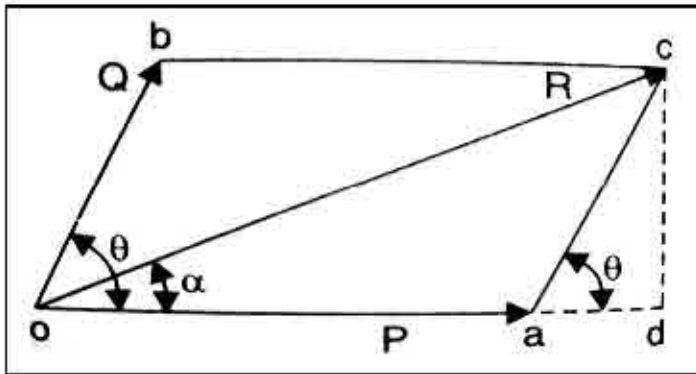

From the geometry of the figure $\angle cad = \theta$, $ac = Q$.

$\therefore cd = Q \sin \theta$ and $ad = Q \cos \theta$.

From right angle triangle, odc

$$oc = \sqrt{(od)^2 + (cd)^2} = \sqrt{(oa + ad)^2 + (cd)^2}$$

$$\text{or } R = \sqrt{(P + Q \cos \theta)^2 + (Q \sin \theta)^2} = \sqrt{P^2 + Q^2 \cos^2 \theta + 2PQ \cos \theta + Q^2 \sin^2 \theta}$$

$$= \sqrt{P^2 + Q^2 (\sin^2 \theta + \cos^2 \theta) + 2PQ \cos \theta}$$

$$= \sqrt{P^2 + Q^2 + 2PQ \cos \theta}$$

i.e. when $\theta = 0^\circ$, $R = P + Q$, When $\theta = 90^\circ$, $R = \sqrt{P^2 + Q^2}$, When $\theta = 180^\circ$, $R = P - Q$

Let the resultant makes an angle α with P as shown in figure, Then

$$\tan \alpha = \frac{cd}{od} = \frac{cd}{oa + ad} = \frac{Q \sin \theta}{P + Q \cos \theta}$$

Example-1

Find the Magnitude and direction of the resultant of the two forces P & Q 50 N and 60 N respectively acting at a point with an included angle of 30° between them. The force 80 N being horizontal.

Ans:- Given:- P = 50 N and Q = 60 N and $\theta = 30^\circ$

Applying the Parallelogram Law Formulae

$$\begin{aligned} R &= \sqrt{P^2 + Q^2 + 2PQ\cos\theta} \\ &= \sqrt{50^2 + 60^2 + 2 \times 50 \times 60 \times \cos 30^\circ} \\ &= \sqrt{2500 + 3600 + 5196.15} \\ &= 106.28 \text{ N} \end{aligned}$$

Hence Magnitude of the resultant force is 106.28 N

$$\begin{aligned} \text{Now } \tan\alpha &= \frac{Q \sin\theta}{P + Q \cos\theta} = \frac{60 \sin 30^\circ}{50 + 60 \cos 30^\circ} \\ &= \frac{30}{50 + 51.96} = 0.294 \end{aligned}$$

Hence $\alpha = \tan^{-1}(0.294) = 16.38^\circ$.

Example-2

The Resultant of two forces P and 30 N is 40 N and is inclined at 60° to the 30 N force. Find the magnitude and direction of P.

Ans:- Considering the ΔOAB ,

$$\begin{aligned} AB^2 &= OA^2 + OB^2 - 2.OA.OB.\cos 60^\circ \\ \Rightarrow P^2 &= 30^2 + 40^2 - 2 \times 30 \times 40 \times \cos 60^\circ \\ \Rightarrow P &= \sqrt{900 + 1600 - 2400 \times 0.5} \\ &= 36.06 \text{ N (Ans)} \end{aligned}$$

Now applying Sine rule,

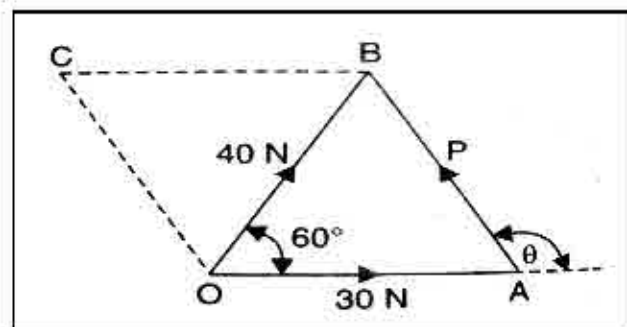

$$\frac{P}{\sin 60^\circ} = \frac{40}{\sin(180^\circ - \theta)}$$

$$\Rightarrow \frac{36.06}{0.866} = \frac{40}{\sin(180^\circ - \theta)}$$

$$\Rightarrow \sin(180^\circ - \theta) = \frac{40 \times 0.866}{36.06} = 0.96$$

$$\Rightarrow 180 - \theta = \sin^{-1} 0.96 = 73.74^\circ = 73^\circ 44'$$

$$\Rightarrow \theta = 106^\circ 16'. \text{ (Ans)}$$

Polygon Law of Forces:-

It states that:

“If a number of coplanar concurrent forces, acting simultaneously on a body are represented in magnitude and direction by the sides of a polygon taken in order, then their resultant may be represented in magnitude and direction by the side of a polygon, taken in the opposite order.”

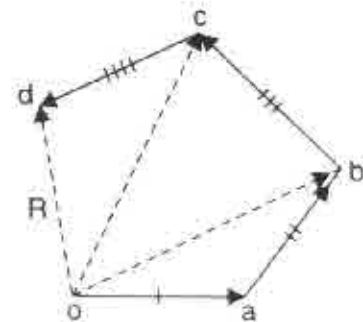
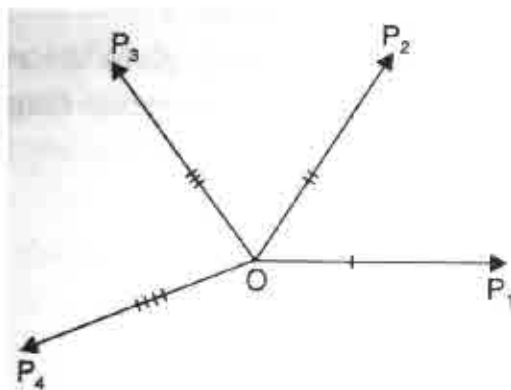

If the forces P_1, P_2, P_3 and P_4 acting simultaneously on a particle be represented in magnitude and direction by the sides oa, ab, bc and cd of a polygon respectively, their resultant is represented by the closing side ' do ' in the opposite direction as shown in the figure.

The law is actually an extension of Triangle law of forces.

This is so because ob is the resultant of oa and ab and therefore oc which is resultant of ob and bc , is also the resultant of oa, ab and bc . Similarly od is the resultant of oc and cd .

So the resultant of the forces P_1, P_2, P_3 and P_4 is ' od ', which is the closing side of the polygon.

PARALLEL FORCES

Force whose line of action are parallel are called parallel forces. They are said to be like when they act in the same sense and are said to be unlike when act in the opposite sense.

(i) Resultant of two like parallel forces:-

As per the figure let the like parallel force P and Q act at the points A and B and their resultant R cut AB at C .

By resolving parallel to P or Q , we get $R = P + Q$,
and that R is parallel to P and Q .

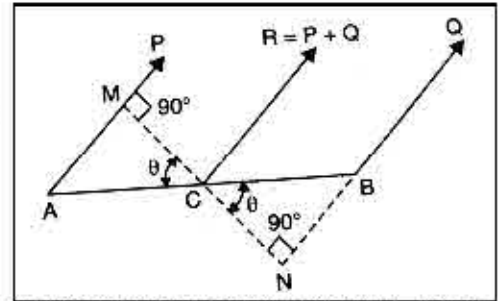

The moment of R about C is zero, so that the algebraic sum of moments of P and Q about C must also be zero.

Through C draw MN perpendicular to P and Q .

Now, $CM = AC \cos\theta$

$CN = BC \cos\theta$

Taking moment about C ,

$P \times CM = Q \times CN$

$\Rightarrow P \times AC \cos\theta = Q \times BC \cos\theta$

$\Rightarrow P \times AC = Q \times BC$

$\Rightarrow P/BC = Q/AC$

$\therefore C$ divides AB internally in the inverse ratio of the forces.

(ii) Resultant of two unlike parallel forces:-

As per the figure Let two unlike parallel force

P and Q act at the points A and B .

Let their resultant R meet AB at C .

Let P be greater than Q .

By resolving parallel to P or Q , we get

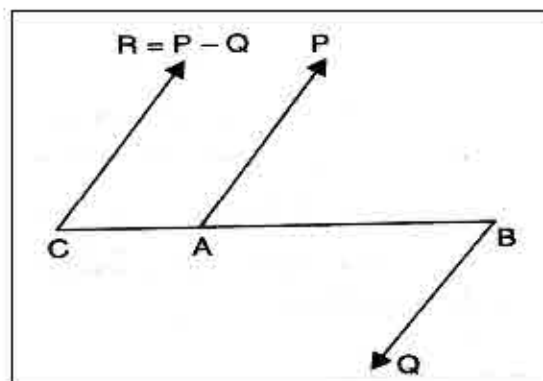

$R = P - Q$, acting in the same sense as P .

The algebraic sum of the moments of P and Q about C must be Zero so that these moments must be equal and opposite. Hence C must lie outside AB , and it must be nearer to A than to B .

Taking moments about C , we get $P \times AC = Q \times BC$.

Or $P/BC = Q/AC$

$\therefore C$ divides AB externally in the inverse ratio of the forces.

The point C is called the Centre of the parallel forces. It is clear that the position of C is independent of the inclination of the forces.

GRAPHICAL METHOD FOR FINDING THE RESULTANT OF ANY NUMBER OF LIKE OR UNLIKE PARALLEL FORCES:-

Referring to fig-(a) P, Q, R, S are the parallel forces, where P, Q and S are in one direction and the force R in the opposite direction.

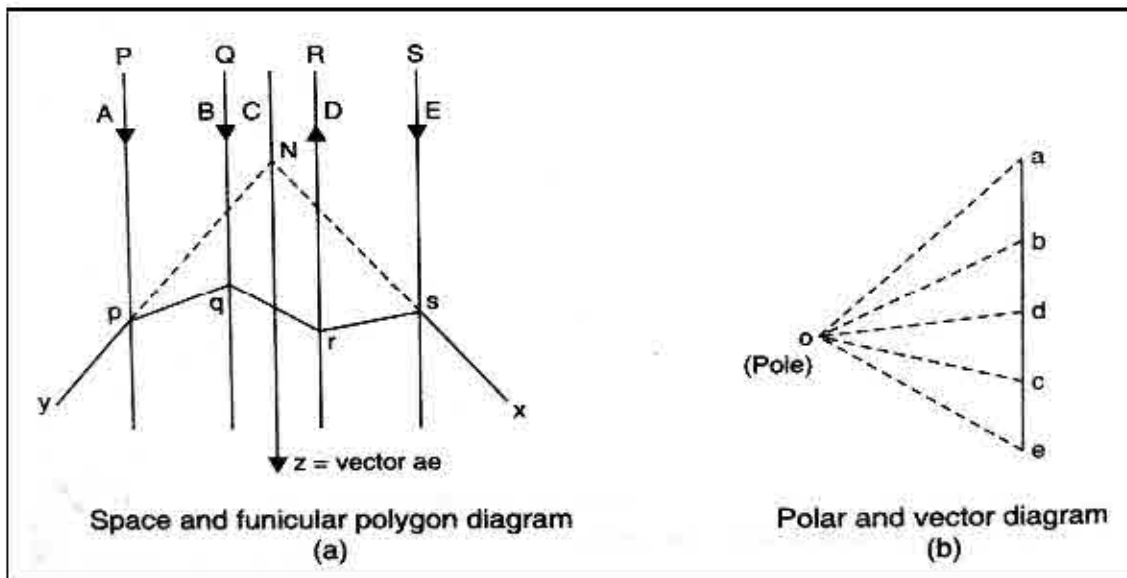

The various steps involved in finding the resultant by graphical method are given below.

- (i) Put letters A, B, C, D and E in the space about P, Q, R, S .
- (ii) To convenient scale mark off ab equal to force P , bc equal to force Q , cd equal to force R , in the opposite direction and de equal to force S .

Ae represents the resultant in magnitude and direction and its line of action is found as follows.

Referring Fig. b

- (i). Take any point O (called pole) outside the vector diagram abcde and join oa, ob, oc, od and oe.
- (ii). Take any point on Force S and the point s in the space E draw a line parallel to oe.
- (iii). Similarly in the spaces D, C, B and A lines sr, rq, and py parallel to od, oc, ob, and oa respectively.
- (iv). Produce lines xs and yp to meet each at N.

The resultant force Z which passes through point N is completely given by ae in the magnitude and direction.

Chapter – 2

Equilibrium of Forces

If the resultant of a number of forces, acting on a particle is zero, the particle will be in equilibrium.

The force, which bring the set of forces in equilibrium is called on equilibrant. The equilibrant is equal to the resultant force in magnitude, but opposite in direction.

Analytical conditions of equilibrium of a co-planner system of concurrent forces.

We know that the resultant of a system of co-planner concurrent forces is given by :

$$R = \sqrt{(\sum x)^2 + (\sum y)^2}, \text{ where } \quad \therefore \quad \sum y = 0$$

$\sum x$ = Algebraic sum of resolved parts of the forces along a horizontal direction.

$\sum y$ = Algebraic sum of resolved parts of the forces along a vertical direction.

$$R^2 = (\sum x)^2 + (\sum y)^2$$

If the forces are in equilibrium, $R=0$

$$0 = (\sum x)^2 + (\sum y)^2$$

Sum of the squared of two quantities is zero when each quantity is separately equal to zero.

$$\therefore \sum x = 0 \text{ and } \sum y = 0$$

Hence necessary and sufficient conditions of a system of co-plan concurrent forces are :

- i) The algebraic sum of the resolved parts of the forces in some assigned direction is equal to zero.
- ii) The algebraic sum of the resolved parts of the forces in a direction nat right angles to the assigned direction is equal to zero.

Graphical conditions of equilibrium of a system of co-planner concurrent forces :

Let a number of forces acting at a point be in equilibrium. Then, it can be said that the resultant of these forces is nil. Hence the length of the closing line of the polygon drawn to represent the given forces taken in orders will be nil. In other words, the length of closing line of the vector diagram drawn with the given forces in orders, is nil. This means the end point of the vector diagram must coincide with the starting point of the diagram. Hence the vector diagram must be a closed figure.

So, graphical condition of equilibrium of a system of co-planner concurrent forces may be stated as follows :

If a system of co-planner concurrent forces be in equilibrium, the vector diagram drawn with the given forces taken in orders, must be a closed figure.

Lami's Theorem :

If three concurrent forces are acting on a body, kept in an equilibrium, then each force is proportional to the sine of the angle between the other two forces and the constant of proportionality is the same.

Consider forces, P, Q and R acting at a point 'O' mathematically, Lami's theorem is given by the following equilibrium :

$$\frac{P}{\sin\alpha} = \frac{Q}{\sin\beta} = \frac{R}{\sin\gamma} = K$$

Since the forces are in equilibrium, the triangle of forces should close, corresponding to the forces, P, Q and R acting at a point 'O'. The angles of the triangle are

$$\begin{aligned} \angle A &= \lambda - \alpha \\ \angle B &= \lambda - \beta \\ \angle C &= \lambda - \gamma \end{aligned}$$

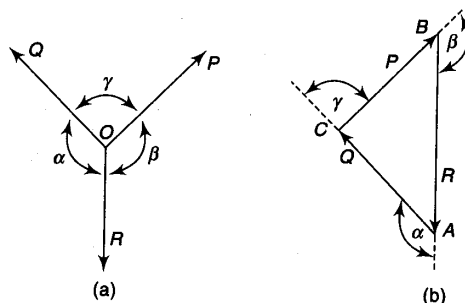

From the rule for the triangle we get.

$$\frac{P}{\sin(\lambda - \alpha)} = \frac{Q}{\sin(\lambda - \beta)} = \frac{R}{\sin(\lambda - \gamma)}$$

$$\sin(\lambda - \alpha) = \sin \alpha$$

$$\sin(\lambda - \beta) = \sin \beta$$

$$\sin(\lambda - \gamma) = \sin \gamma$$

Or we can write the equation (1) according to Lami's Theorem i.e.

$$\frac{P}{\sin \alpha} = \frac{Q}{\sin \beta} = \frac{R}{\sin \gamma}$$

Example :

An electric light fixture weighing 15 N hangs from a point C, by two strings AC and BC. The string AC is inclined at 60° to the horizontal and BC at 45° to the vertical as shown in figure, using lami's theorem determine the forces in the strings AC and BC.

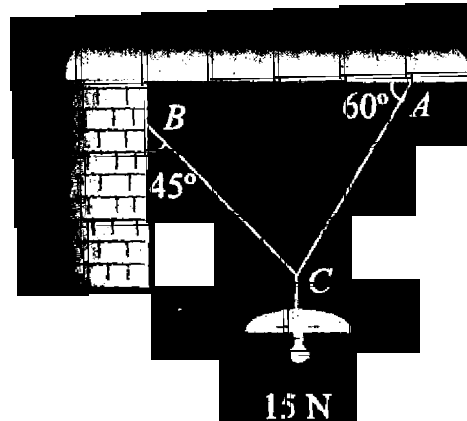

Solution :

Given weight at C = 15 N

T_{AC} = Force in the string AC.

T_{BC} = Force in the string BC.

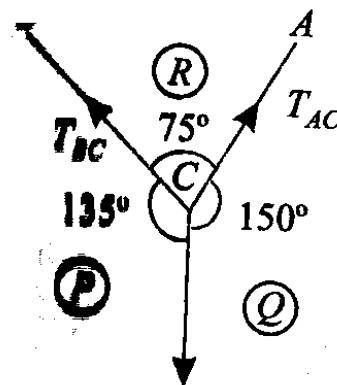

According to the system of forces and the above figure, we find that angle between T_{AC} and ISN is 150° and angle between T_{BC} and 15 N is 135° .

$$\angle ACB = 180^\circ - (40^\circ + 60^\circ) = 75^\circ$$

Applying Lami's Theorem :

$$\frac{15}{\sin 75^\circ} = \frac{T_{AC}}{\sin 135^\circ} = \frac{T_{BC}}{\sin 150^\circ}$$

$$\therefore T_{AC} = \frac{15 \sin 135^\circ}{\sin 75^\circ} = 10.98\text{ N (Ans)}$$

$$\text{and } T_{BC} = T_{BC} = \frac{15 \sin 150^\circ}{\sin 75^\circ} = 7.76\text{ N (Ans)}$$

Body Diagram :

Free body diagram is a sketch of the isolated body, which shows the external forces on the body and the reaction extended on it by the removed elements.

The general procedure for constructing a free body diagram is as follows :

1. A sketch of the body is drawn, by removing the supporting surfaces.
2. Indicate on this sketch all the applied on active forces which send to set the body in motion, such as those caused by weight of the body on applied forces etc.
3. Also indicate on this sketch all the reactive forces, such as those caused by the constrains or supports that tend to prevent motion. (The sense of unknown reaction should be assumed. The correct sense will be determined by the solution of the problem. A positive result indicates that the assumed sense is correct A negative results indicates that the correct sense is opposite to the assumed sense).
4. All relevant dimensions and angles, reference axes are shown on the sketch.

Example :

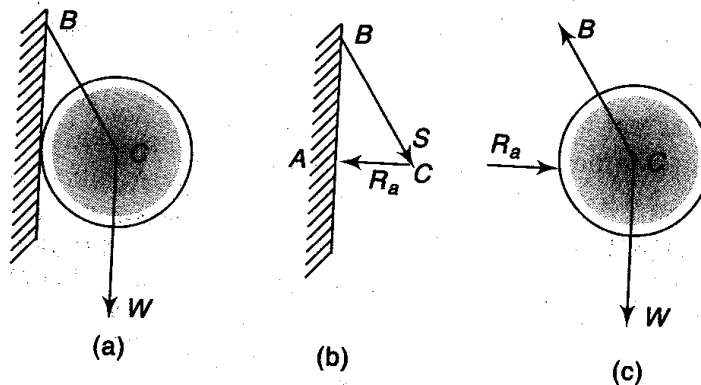

CHAPTER – 3

FRICTION

When a body moves or trends to move over another body, an opposing force develops at the contact surface. This force opposes the movement is called frictional force or friction.

Frictional force is the resistance offered when a body moves over another body assist the motion.

There is a limit beyond which the magnitude of this force cannot increase when applied force more than this limit there will be motion. When applied force less than this limit value, the body remains at rest and such frictional force is called static friction. When body moves (applied force more than limiting friction) the frictional resistance is known as Dynamic friction.

Dynamic friction is found less than limiting friction.

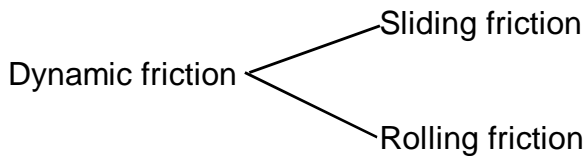

Coefficient of friction :

Experimentally found that the magnitude of limiting friction bears a constant ratio to the normal reaction between the two surfaces and this ratio is called coefficient of friction :

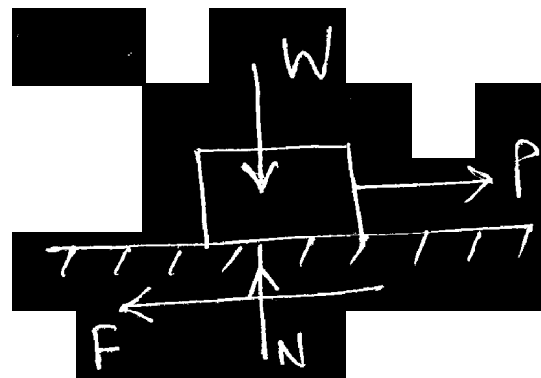

$$\text{Co-efficient of friction} = F/N = \mu$$

F → Limiting friction (Frictional force)

N → Normal reaction

Laws of friction :

- 1) Force of friction is directly proportional to the normal reaction and always opposite in the direction of motion.
- 2) Force of friction depends upon the roughness/ smoothness of the surface.

- 3) Force of friction is independent of the areas of the contact.
- 4) Force of friction is independent of the sliding velocity.

Angle of friction :

Consider the block 'A' resting on horizontal plane 'B'.

Let, $P \rightarrow$ horizontal force applied.

$F \rightarrow$ Frictional force

$N \rightarrow$ Normal reaction.

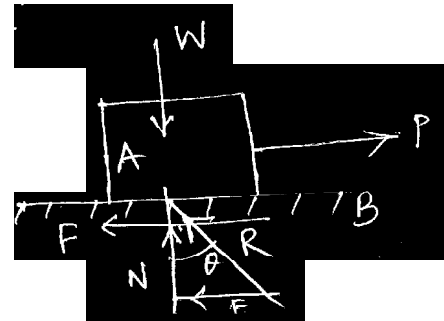

Let R be the resultant reaction between normal reaction and force of friction acts at angle θ to the normal Reaction. $\theta \rightarrow$ Angle of friction.

$$\tan \theta = F/N$$

As P increases, F increases and hence θ also increases. θ can reach the maximum value α when F reaches limiting value

$$\tan \alpha = F/N = \mu$$

$\alpha \rightarrow$ Angle of friction. (Angle of limiting friction)

Angle of Repose :

It is the maximum inclined plane with the horizontal for which a body lying on the inclined plane will be on the point of sliding down.

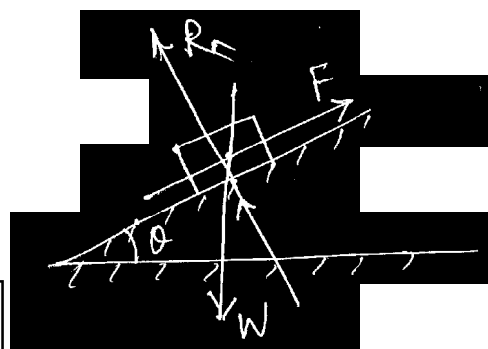

Angle of Repose is equal to the angle of friction .

Consider a block of weight 'W' resting on a rough inclined plane (angle)

$R_n \rightarrow$ Normal reaction

$f \rightarrow$ Frictional force

$$F = W \sin \alpha, R_n = W \cos \alpha$$

$$\tan \alpha = \frac{F}{R_n}$$

But we knew that $\tan \phi = \frac{E}{Rn} = \mu$

Tan $\alpha = \text{Tan } \phi$ $\alpha = \phi$

Ex - 1

A body resting on a horizontal plane can be moved slowly along the plane by a horizontal force of 10 KN. A force of a 9 KN inclined at 30° to the horizontal direction will suffice to move the block along the same direction. Determine the co-efficient of friction and weight of the body.

Solution :

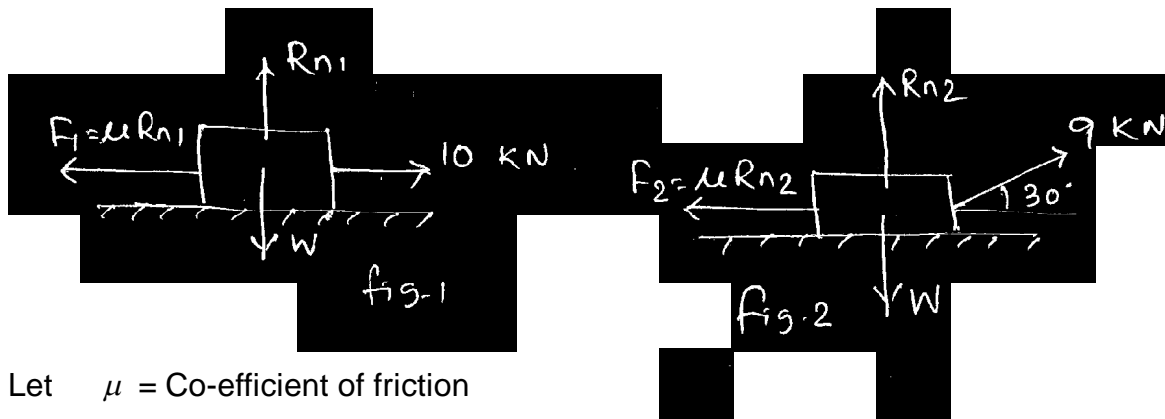

Let $\mu =$ Co-efficient of friction
 $W =$ Weight of the body.

From fig-1

$F_1 = \mu R_{n1} = 10$ -----(1)

$R_{n1} = W$ -----(2)

So $\mu W = 10$ ----- (3)

$9 \cos 30^\circ = F_2 = \mu R_{n2}$ ----- (4)

$R_{n2} + 9 \sin 30 = W$ ----- (5)

$R_{n2} = W - 4.5$ ----- (6)

Putting the value of R_{n2} in equation(4)

$\mu [W-4.5] = 9 \cos 30^\circ = 7.794$

$\mu W - \mu 4.5 = 7.794$ ----- (7)

Putting the value of μW from (3)

$10 - \mu 4.5 = 7.794$

$\mu 4.5 = 10 - 7.794$ $\mu = 0.49$

Putting the value of μ in equation (3)

$$.49 W = 10$$

$$W = 20.408 \text{ KN.}$$

A body resting on rough horizontal plane, required a pull of 18 KN at 30° to the plane just to move it. It was also found that a push of 22 KN inclined at 30° to the plane just moved the body. Determine the weight of the body and co-efficient of friction.

Solution :

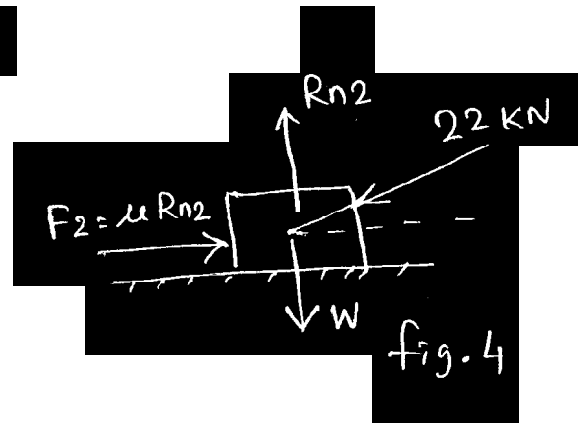
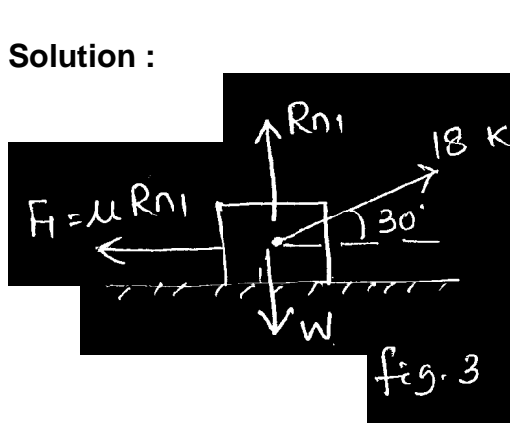

Let $W \rightarrow$ Weight of the body

$\mu \rightarrow$ Co-efficient of friction

From fig - 3

$$F_1 = \mu R_{n1} = 18 \cos 30^\circ = 15.59 \text{ KN} \text{ -----(1)}$$

$$R_N + 18 \sin 30^\circ = W$$

$$R_N = W - 9 \text{ ----- (2)}$$

Putting the value of equation (2) in equation (1)

$$\mu (W-9) = 15.59 \text{ -----(3)}$$

From fig. 4.

$$F_2 = \mu R_{n2} = 22 \cos 30 = 19.05 \text{ -----(4)}$$

$$R_{n2} = W + 22 \sin 30^\circ = W + 11 \text{ -----(5)}$$

Putting the value of equation (5) in equation (4)

$$\mu (W+11) = 19.05 \text{ -----(6)}$$

From equation (3) and equation (6)

$$\mu = \frac{15.59}{W-9}, \mu = \frac{19.05}{W+11}$$

$$\frac{15.59}{19.05} = \frac{W-9}{W+11}$$

Ladder friction :

It is a device for climbing up or down.

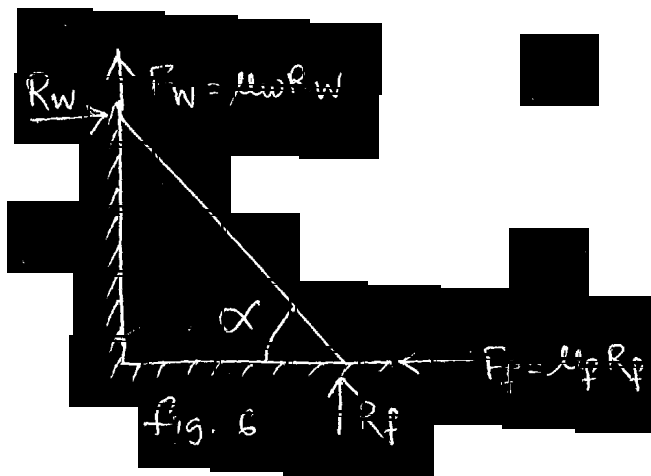

Since this system is in equilibrium, the algebraic sum of the horizontal and vertical component of the forces must be zero and the algebraic sum of the moment must also be zero.

$$\Sigma F_x = 0, \Sigma F_y = 0, \Sigma M = 0$$

Ex – 5

A ladder of length 4m, weighing 200N is placed against a vertical wall as shown in fig. 7. The co-efficient of friction between the wall and the ladder is 0.2 and that between the floor and the ladder is 0.3. In addition to self weight, the ladder has to support a man weighing 600N at a distance of 3 m. from A calculate the minimum horizontal force to be applied at A to prevent slipping.

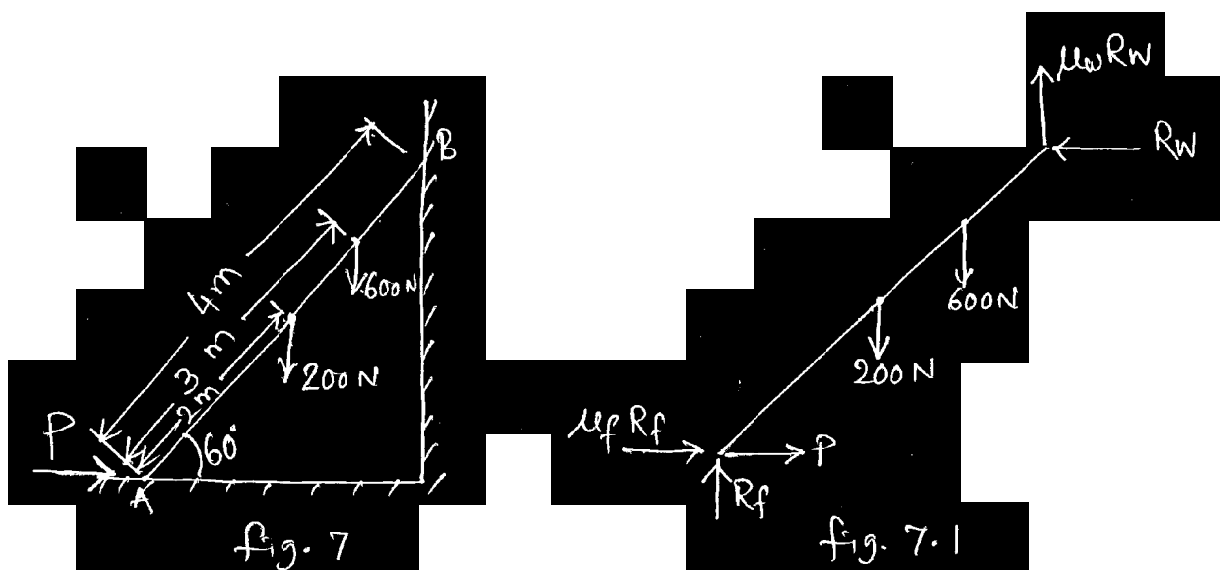

Solution :

The FBD of the ladder is shown in fig. 7.1

Taking moment at A

$$R_w \times 4 \sin 60^\circ + \mu w R_w \times 4 \cos 60$$

$$= 600 \times 3 \cos 60 + 200 \times 2 \cos 60$$

$$866 R_w + 0.2 \times 0.5 R_w = 275$$

$$0.966 R_w = 275$$

$$R_w = 284.68 \text{ -----(1)}$$

$$600 + 200 = R_f + \mu w R_w$$

$$R_f = 800 - 0.2 \times 284.68$$

$$= 743.06 \text{ ----- (2)}$$

$$P + \mu f R_f = R_w$$

$$P = 284.68 - 0.3 \times 743.06 = 61.76$$

Ex – 6

The ladder shown in fig. 8 is 6m. long and is supported by a horizontal floor and vertical wall. The co-efficient of friction between the floor and the ladder is 0.25 and between the wall and the ladder is 0.4 The self weight of the ladder is 200 N. The ladder also supports a vertical load of 900 N at C which is at a distance of 1 m from B. Determine the least of value of α at which the ladder may be placed without slipping.

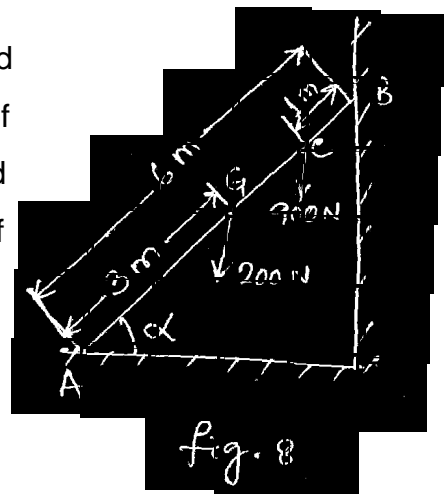

Solution :

μw = Co-efficient of friction between wall and ladder = 0.4

μf = Co-efficient of friction between floor and ladder = 0.25

The FBD of the ladder is shown in fig. 8.1

$$R_w = \mu f R_f = 0.25 R_f \text{ ----- (1)}$$

$$R_f + \mu w R_w = 900 + 200 = 1100$$

$$R_f + 0.4 \times 0.25 R_f = 1100$$

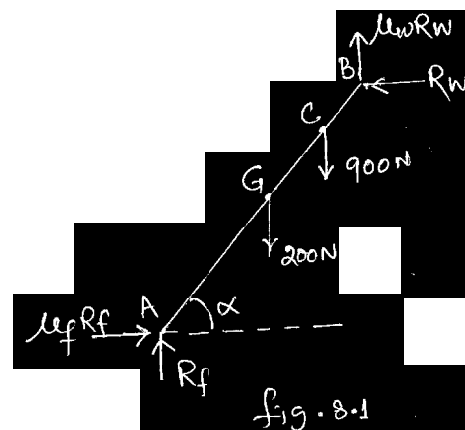

$$R_f = 100 \text{ N} \text{ ----- (2)}$$

$$\text{So } R_w = 250 \text{ N} \text{ ----- (3)}$$

Taking moment about A

$$R_w \times 6 \sin \alpha + \mu_w R_w \times 6 \cos \alpha$$

$$= 200 \times 3 \cos \alpha + 900 \times 5 \cos \alpha$$

$$250 \times 6 \sin \alpha + 0.4 \times 250 \times 6 \cos \alpha = 600 \cos \alpha + 4500 \cos \alpha$$

$$1500 \sin \alpha = 4500 \cos \alpha$$

$$\tan \alpha = 3$$

$$\alpha = 71.563^\circ$$

Ex - 7

A uniform ladder of 4m length rests against a vertical wall with which it makes an angle of 45° . The co-efficient of friction between the ladder and wall is 0.4 and that between ladder and the floor is 0.5. If a man, whose weight is half of that of the ladder ascends it, how height will it be when the ladder slips ?

Solution :

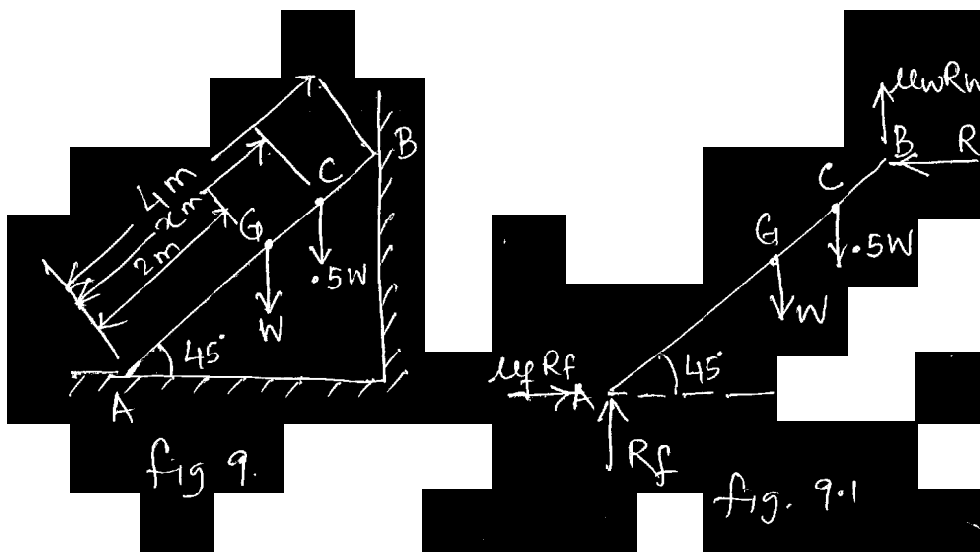

The FBD is shown in fig. 9.1

$$\mu_f = 0.5, \mu_w = 0.4$$

$$\mu_f R_f = R_w$$

$$.5 R_f = R_w \text{ -----(1)}$$

$$R_f + \mu_w R_w = w + 0.5 w = 1.5w$$

$$R_f + .5 \times .4 R_f = 1.5 w$$

$$1.2 R_f = 1.5 w$$

$$R_f = 1.25 w \text{ -----(2)}$$

$$R_w = .5 \times 1.25 w = 0.625w \text{ -----(3)}$$

Taking moment about A

$$R_w \times 4 \sin 45 + \mu w R_w 4 \cos 45^\circ = w \times 2 \cos 45 + .5 w x \cos 45^\circ$$

$$4 R_w + \mu w 4 R_w = 2W + .5 x w$$

$$4 \times .625 w + .4 \times 4 \times 0.625 w = 2 w + .5 x w$$

$$2.5 + 1 = 2 + .5x$$

$$.5 x = 1.5$$

$$x = 3 \text{ m.}$$

Wedge friction :

Wedges are generally triangular or trapezoidal in cross section. It is generally used for tightening keys or shaft. It is also used for lifting heavy weights. The weight of the wedge is very small compared to the weight lifted.

Let w = weight of the block

P = Force required to lift the load

μ = co-efficient of friction on all contact surface.

α = Wedge angle.

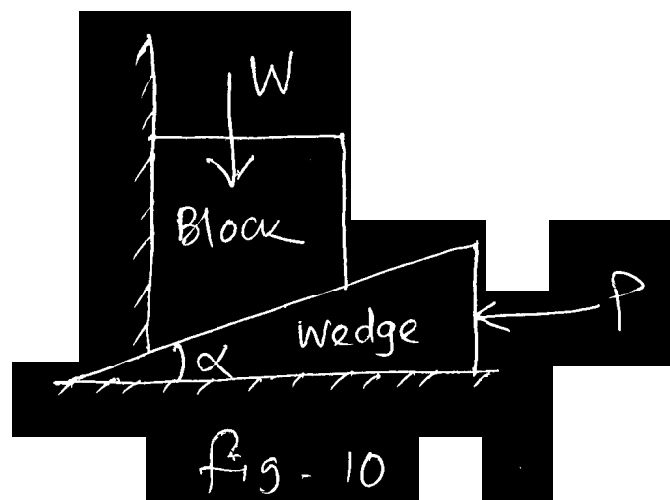

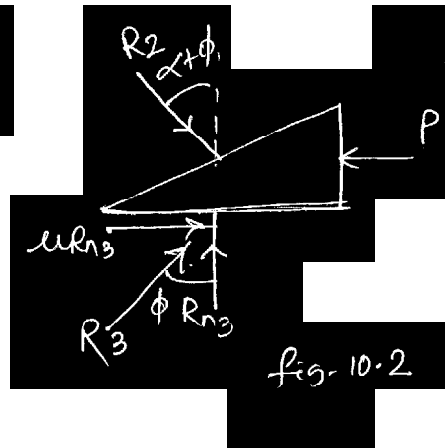
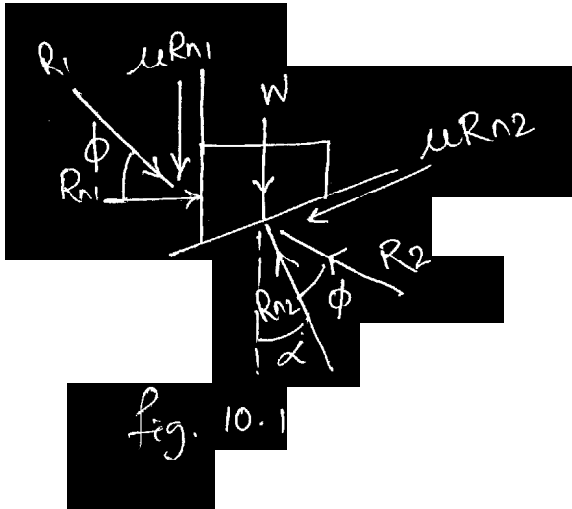

Considering the FBD of fig. 10.1 under the action of 3 forces the system is in equilibrium.

- 1) $R_1 \rightarrow$ Resultant friction of normal reaction and force of friction between block and wall.
- 2) $W \rightarrow$ Weight of the block.
- 3) $R_2 \rightarrow$ Resultant reaction of normal reaction and force of friction between contact surface of block and wedge.

Applying Lami's Theorem

$$\frac{W}{\sin[90 + (\alpha + \phi)]} = \frac{R_1}{\sin[180 - (\alpha + \phi)]} = \frac{R_2}{\sin(90 - \phi)}$$

$$\text{or } \frac{W}{\cos(\alpha - 2\phi)} = \frac{R_1}{\sin(\alpha + \phi)} = \frac{R}{\cos\phi}$$

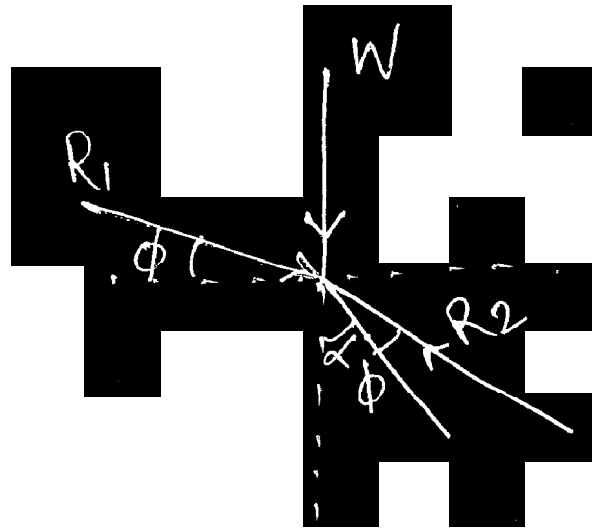

Again considering the FBD of Fig. 10.2 under the action of 3 forces the system is in equilibrium.

- 1) $R_2 \rightarrow$ Reaction given by the block.
- 2) $P \rightarrow$ Force applied on wedge.

3) $R_3 \rightarrow$ Resultant reaction of normal reaction and force of friction between wedge and floor.

Applying Lami's theorem

$$\frac{P}{\sin(\alpha + 2\phi)} = \frac{R_2}{\cos\phi} = \frac{R_3}{\cos(\alpha + \phi)}$$

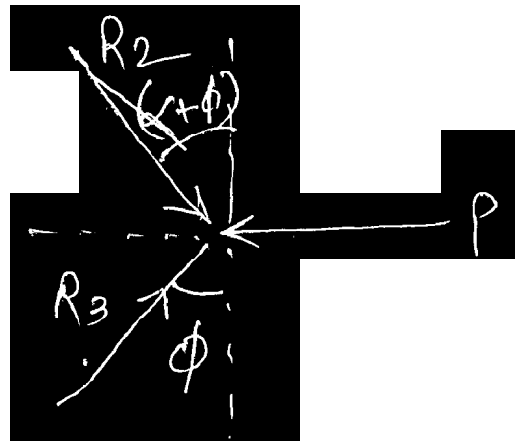

Chapter – 4

Centre of gravity – It is the point where whole of the mass of a body is supposed to act. In other words it is the point through which resultant of the parallel forces of attraction formed by the weight of the body, passes.

It is usually denoted by CG or simply G.

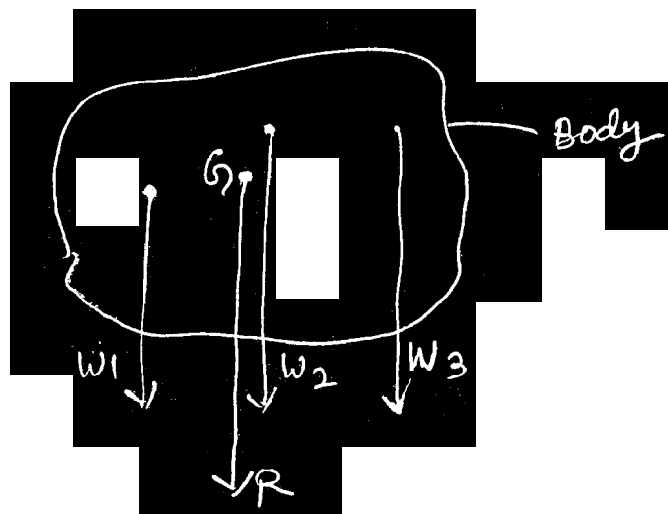

Centroid :

It is the point where the whole area of a body is assumed to be concentrated. Plane figures (known as laminas) have area only but no mass. The centre of gravity and centroid of such figures are the same point.

For plane areas, centroid is represented by two coordinates by selecting coordinate axes in the plane of the area itself.

The two co-ordinate axes are usually selected in the extreme left and bottom of the area.

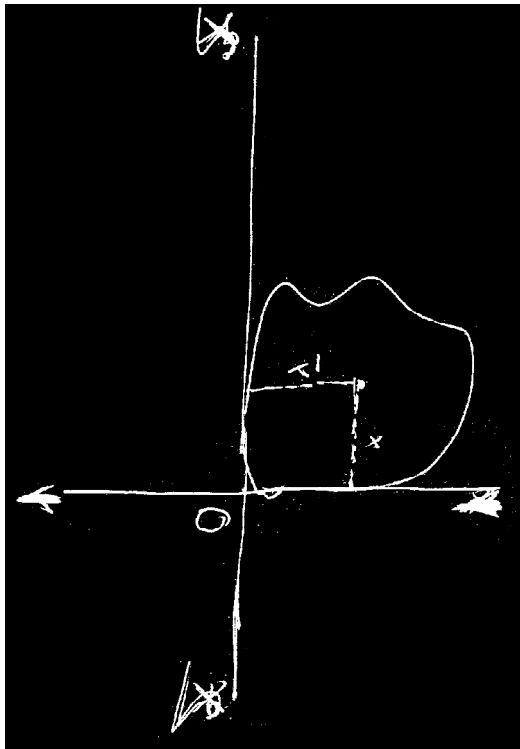

Mathematically (continuous form)

$$\bar{x} = \frac{\int_A x \cdot dA}{A}$$

Similarly $\bar{y} = \frac{\int_A y \cdot dA}{A}$

$\int_A x dA$ and $\int_A y dA$ are known as first moment of area about x & y axes respectively.

Mathematically – (Discrete form)

$$\bar{x} = \frac{\sum_{i=1}^n \Delta A_i X_i}{\sum_{i=1}^n \Delta A_i}$$

$$\bar{y} = \frac{\sum_{i=1}^n \Delta A_i Y_i}{\sum_{i=1}^n \Delta A_i}$$

Ex - 1

Determine the y - co-ordinate of the centroid of a uniform triangular lamina.

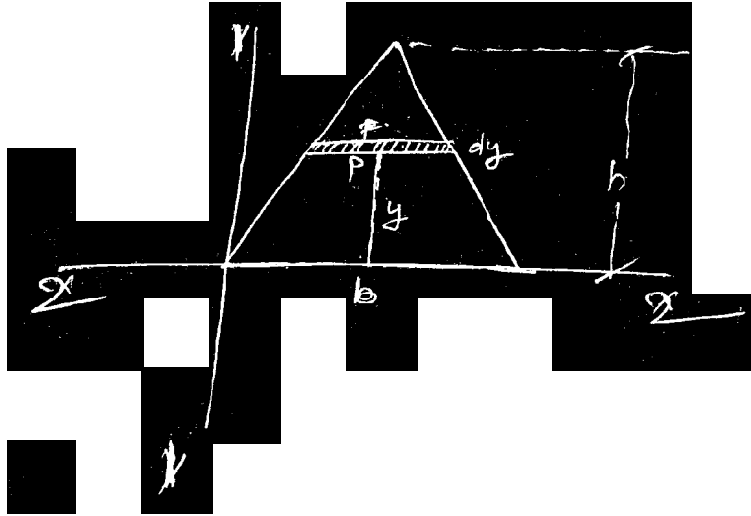

From the concept of similar triangles.

$$\frac{p}{b} = \frac{h-y}{h}$$

$$\therefore P = \left(\frac{h-y}{h}\right)b$$

$$\therefore \text{The area of the shaded portion } dA = \left(\frac{h-y}{h}\right)b.dy$$

$$\therefore \bar{y} = \frac{\int y.dA}{A}$$

$$= \frac{\int_0^y y\left(\frac{h-y}{h}\right)b.dy}{\frac{1}{2} \times b.h}$$

$$= \frac{\int_0^h y.b(1-y/h)b.dy}{\frac{bh}{2}}$$

$$= \frac{\int_0^h y\left(1-\frac{y}{h}\right)dy}{\frac{bh}{2}}$$

$$\begin{aligned}
&= \frac{2}{h} \left[ydy - \frac{y^2}{h} dy \right] \\
&= \frac{2}{h} \times \left[\frac{y^2}{2} - \frac{1}{h} \times \frac{y^3}{3} \right]_0^h \\
&= \frac{2}{h} \left(\frac{h^2}{2} - \frac{1}{h} \times \frac{h^3}{3} \right) = \left(\frac{2}{h} \times \frac{h^2}{2} - \frac{2}{h} \times \frac{h^3}{3h} \right) \\
&= h - \frac{2}{3}h \\
&= \frac{3h - 2h}{3} = h/3
\end{aligned}$$

Ex- 2

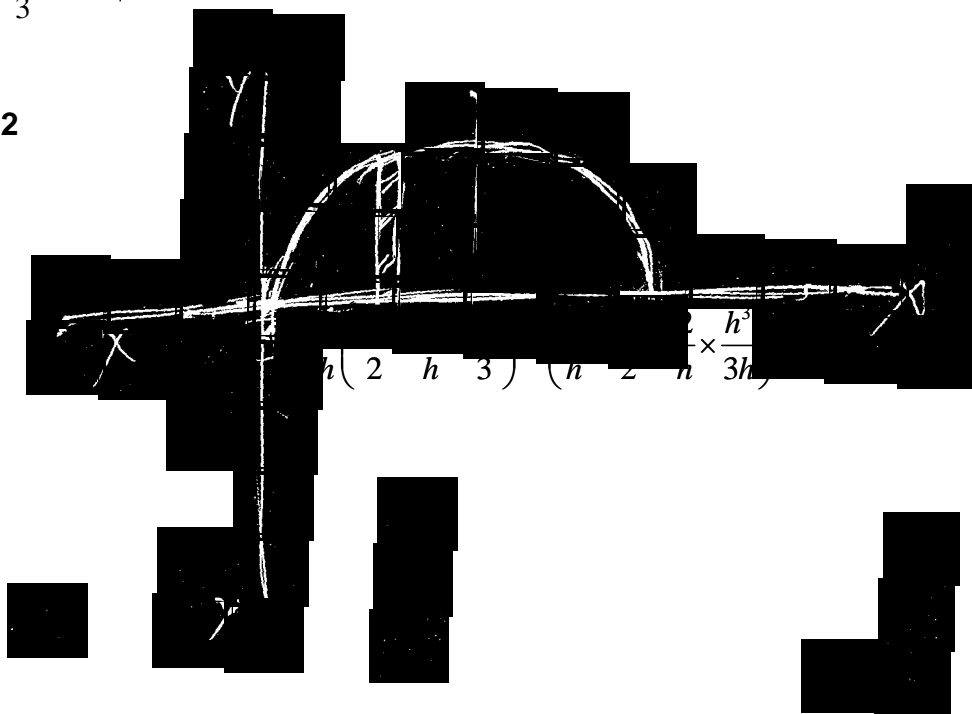

$$\bar{x} = \frac{\int x dA}{\int dA}$$

$$\bar{y} = \frac{\int y dA}{\int dA}$$

A - Centre of gravity of some common figures :

Sl. No.

Plane Figure

C.G. location

1		$\bar{x} = \frac{b}{2}$ $\bar{y} = \frac{d}{2}$
2		$\bar{x} = \frac{b}{2}$ $\bar{y} = \frac{h}{3} \text{ (from base)}$
3		$\bar{x} = \frac{b}{2}$ $\bar{y} = \frac{h}{3} \left(\frac{b+2a}{b+a} \right)$
4		$\bar{x} = r$ $\bar{y} = \frac{4r}{3\pi}$
5		$\bar{y} = \frac{2}{3} r \frac{\sin \alpha}{\alpha}$

B - Centre of gravity of built up symmetrical sections.

Built up sections are formed by combining plane sections. The centre of gravity of such built up sections are calculated using method of moments.

The entire area of the builtup section is divided into elementary plane areas i.e. a_1, a_2, a_3 etc. Two reference axes are selected and let the distance of c.g. of these areas be x_1, x_2, x_3, \dots etc. respectively.

Let G be the centre of gravity of the entire area A and let the distances be \bar{x} and \bar{y} from y axis and x axis respectively.

Thus $A = a_1 + a_2 + a_3 + \dots$

Now sum of moment of all the individual areas about y-y axis.

$$= a_1x_1 + a_2x_2 + a_3x_3 + \dots$$

and the moment of entire area about y y axis = $A\bar{x}$

Now equalising the two moment

$$A\bar{x} = a_1x_1 + a_2x_2 + a_3x_3 + \dots$$

$$\therefore \bar{x} = \frac{a_1x_1 + a_2x_2 + a_3x_3 + \dots}{A}$$

$$\frac{a_1x_1 + a_2x_2 + a_3x_3 + \dots}{a_1 + a_2 + a_3}$$

Similarly

$$\bar{y} = \frac{a_1y_1 + a_2y_2 + a_3y_3 + \dots}{a_1 + a_2 + a_3}$$

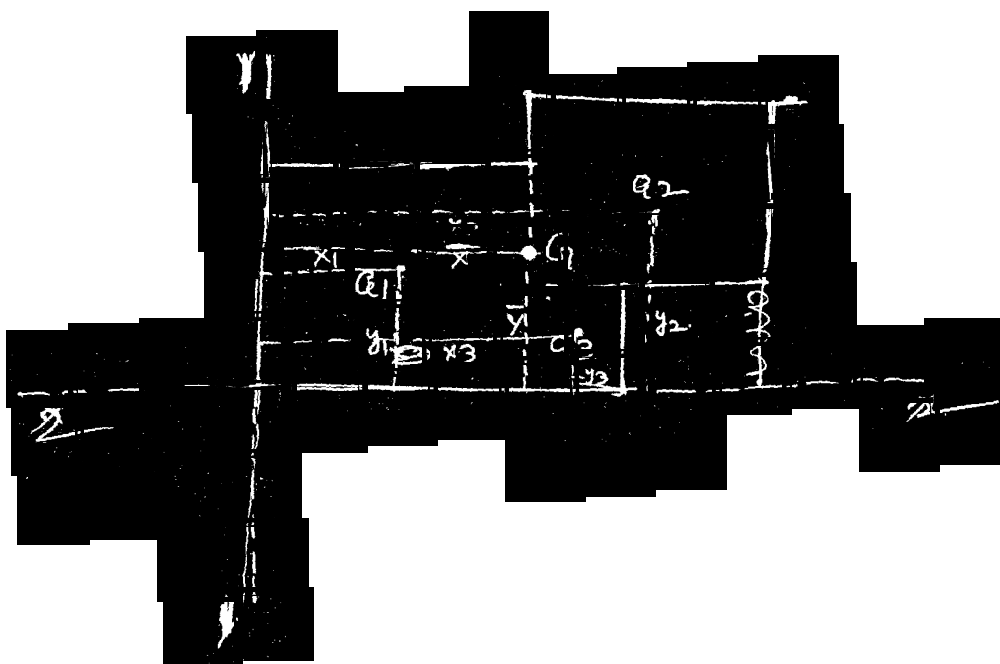

Example :

Locate the centre of gravity of a T-Section having dimension
100mm x 150mm x 20mm

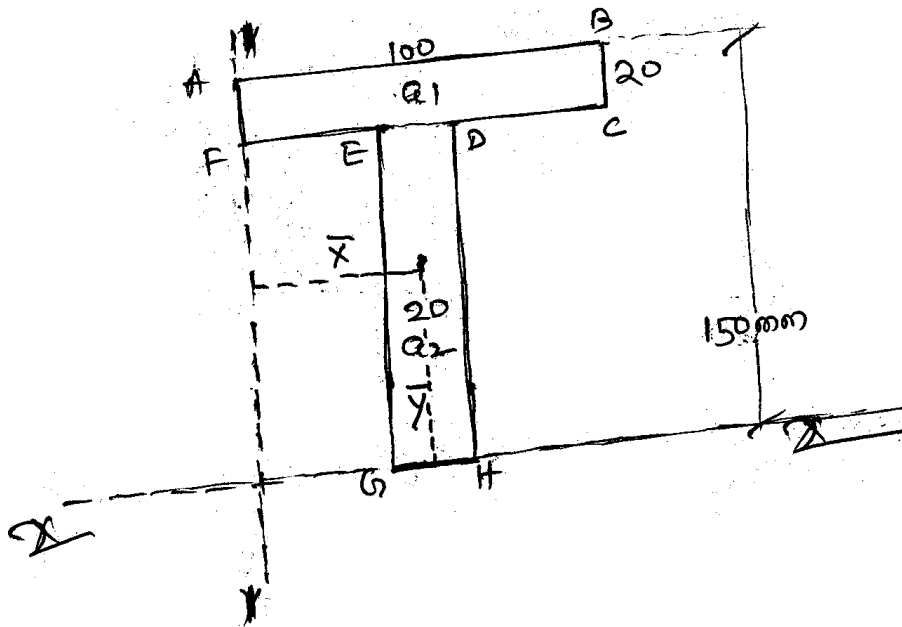

Two reference axes are selected i.e. y-y and x-x at the extreme left and bottom of the given section.

The entire area of the T- Section is divided into two portions.

i.e.

$a_1 =$ Area of the rectangle ABCD

$$= 100 \times 20$$

$$= 2000 \text{ mm}^2$$

$y_1 =$ Distance of c.g. of the rectangle ABCD from x-x axes

$$= 140 \text{ mm}$$

$a_2 =$ Area of the rectangle EDHG

$$= 20 \times 130$$

$$= 2600 \text{ mm}^2$$

$y_2 =$ distance of c.g. of the rectangle EDHG from x-x axes

$$= 65 \text{ mm}$$

$$\therefore \bar{y} = \frac{a_1 y_1 + a_2 y_2}{a_1 + a_2}$$

$$= \frac{2000 \times 140 + 2600 \times 65}{2000 + 2600} = \frac{280000 + 169000}{4600}$$

$$= 97.61 \text{ mm}$$

As the given T-section is symmetrical about y-y axis,

$$\bar{x} = 50 \text{ mm}$$

Centre of gravity of section with cutout

Many a times some portions of a section are removed and thus the centre of gravity of the remaining portion is shifted to new locations.

The c.g. of such a section with cutout can be found out by considering the entire section first and then deducting the cutout section.

If the area of the main section and cut out are a_1 and a_2 respectively and c.g. distances are x_1, y_1 and x_2, y_2 from the reference lines, then the C.G. of the out section from the reference lines.

$$\bar{x} = \frac{a_1 x_1 - a_2 x_2}{a_1 - a_2}$$

&

$$\bar{y} = \frac{a_1 y_1 - a_2 y_2}{a_1 - a_2}$$

Ex-

An isosceles triangle of side 200 mm has been cut from a square ABCD of side 200 mm as per the figure given below. Find out the c.g. of the shaded area.

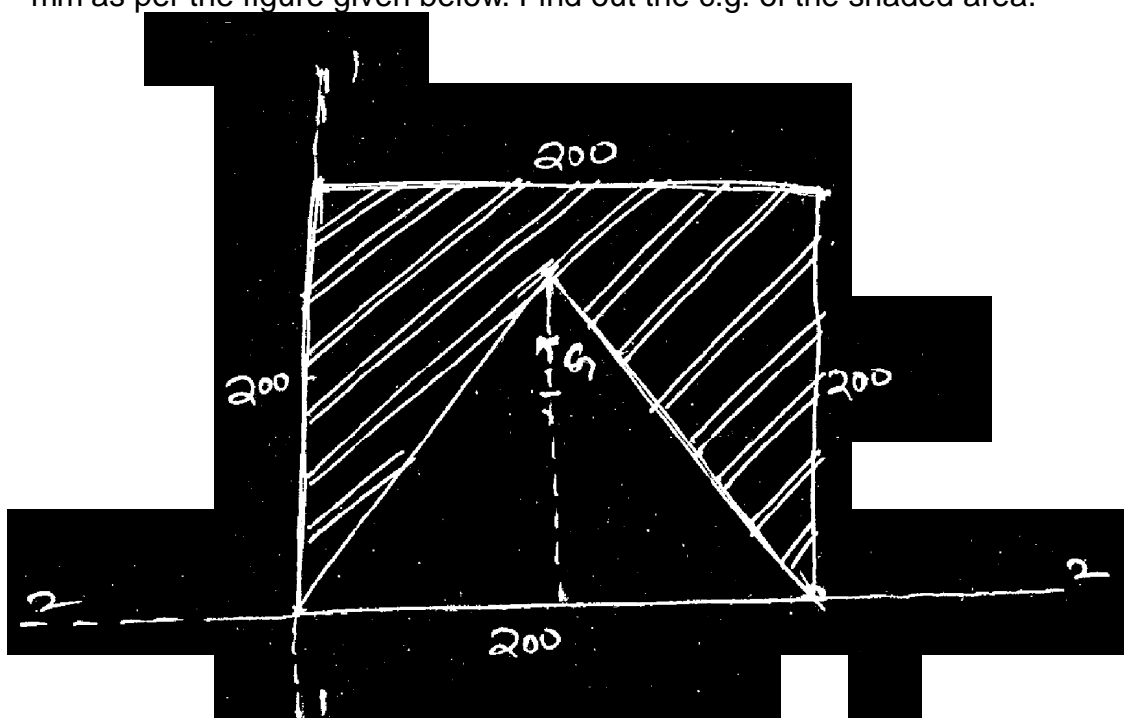

Here,

$$a_1 = 200 \times 200 \\ = 40,000 \text{ sqmm}$$

$$x_1 = 100 \text{ mm}$$

$$y_1 = 100 \text{ mm}$$

$$a_2 = 1/2 \times 200 \times 173.2 \\ = 17,320$$

$$x_2 = 100$$

$$y_2 = 173.2 / 3 \\ = 57.73 \text{ mm.}$$

$$\therefore \bar{x} = \frac{a_1 x_1 - a_2 x_2}{a_1 - a_2} \\ = \frac{40,000 \times 100 - 17,320 \times 100}{40,000 - 17,320} \\ = 100 \text{ mm}$$

$$\bar{y} = \frac{40,000 \times 100 - 17,320 \times 57.73}{40,000 - 17,320} \\ = \frac{4,000,000 - 999,883.60}{22,680} \\ = 132.28 \text{ mm}$$

Ex

Locate the centroid of the cut out section (Shaded area) as shown in the figure.

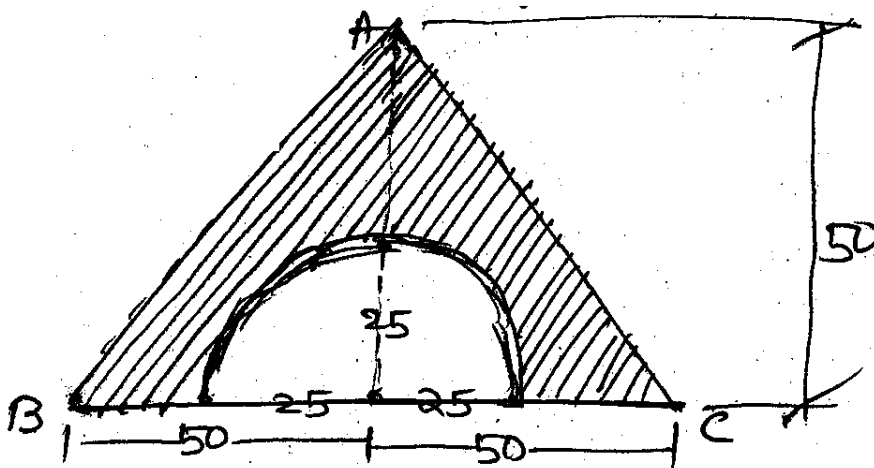

Here

$$a_1 = \frac{1}{2} \times 100 \times 50$$

$$= 2500 \text{ sqmm}$$

$$y_1 = \frac{h}{3}$$

$$= \frac{50}{3}$$

$$= 16.67 \text{ mm}$$

$$a_2 = \frac{\pi r^2}{2}$$

$$= \frac{\pi \times 25^2}{2}$$

$$= 981.75 \text{ mm}^2$$

$$y_2 = \frac{4r}{3\pi}$$

$$= \frac{4 \times 25}{3 \times \pi}$$

$$= 10.61 \text{ mm}$$

$$\therefore y_1 = \frac{a_1 y_1 - a_2 y_2}{a_1 - a_2}$$

$$= \frac{2500 \times 16.67 - 981.75 \times 10.61}{2500 - 981.75}$$

$$= \frac{41675 - 10,416.37}{1518.25}$$

$$= 20.6 \text{ mm}$$

Moment of inertia (Second moment) of an area :

Moment of inertia of any plane area A is the second moment of all the small areas dA comprising the area A about any axis in the plane of area A.

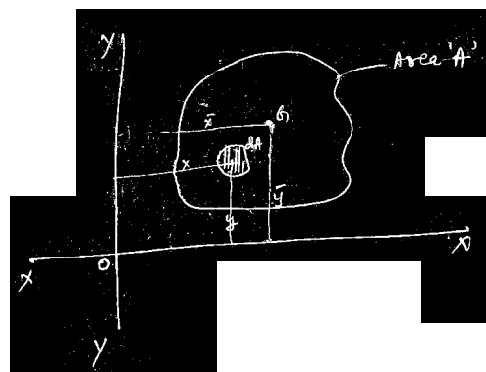

Referring to the figure :

$$\begin{aligned} I_{yy} &= \text{moment of inertia about the axis } y-y \\ &= \sum x^2 dA \\ &= \int x^2 dA \end{aligned}$$

Similarly :

$$\begin{aligned} I_{xx} &= \text{Moment of inertia about the axis } x-x \\ &= \sum y^2 dA \\ &= \int_A y^2 dA \end{aligned}$$

Parallel axis theorem

If the moment of inertia of a plane area about an axis through the centroid is known, the moment of inertia about any other axis parallel to the given centroidal axis can be found out by parallel axis theorem. It states that if I_{cg} is the moment of inertia about the centroidal axis, then moment of inertia about any other parallel axis say AB at a distance of x from the centroidal axis is given by.

$$I_{AB} = I_{xx} + Ax^2$$

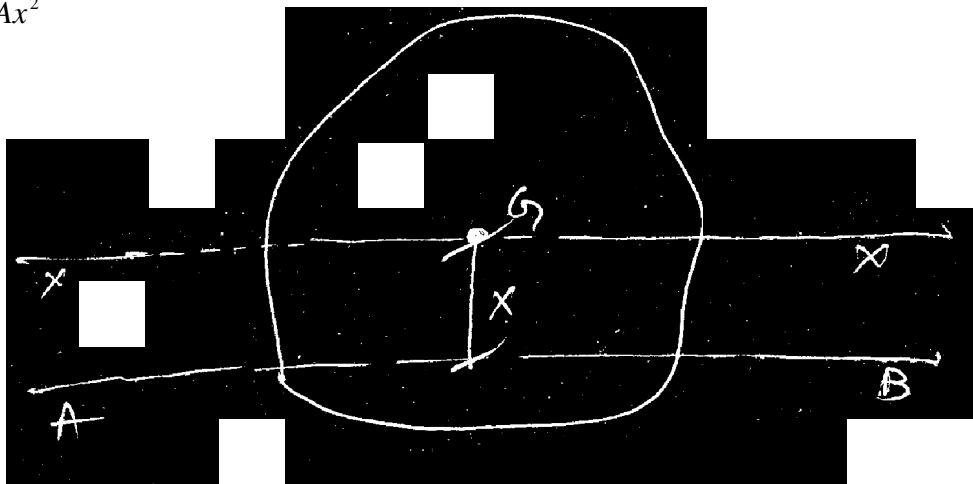

Perpendicular axis theorem

It states that second moment of an area about an axis perpendicular to the plane of the area through a point is equal to the sum of the second moment of areas about two mutually perpendicular axes through that point.

The second moment of area about an axis perpendicular to the plane of the area is known as polar moment of inertia.

$$I_{zz} = I_{xx} + I_{yy}$$

Moment of inertia of a rectangular section :

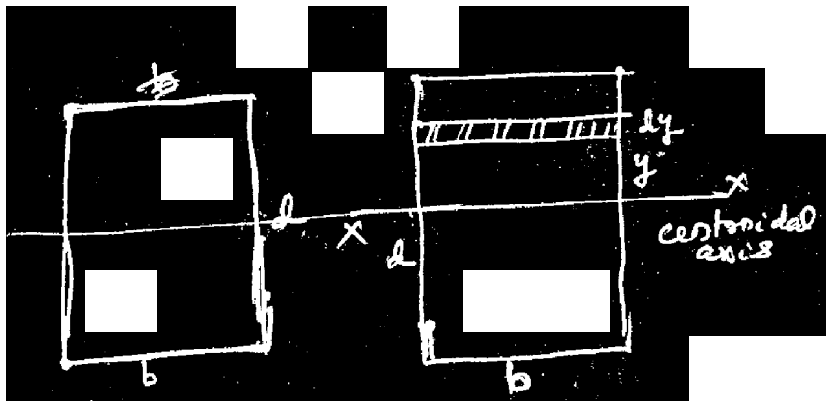

Let us consider as elementary strip of thickness dy at a distance of y from the centroidal axis $x-x$.

\therefore Area of the strip of this elementary area = $b \cdot dy$

& MI about $x-x$ axis = $A \cdot y^2$

$$= b \cdot dy \cdot y^2$$

Now M.I. of the entire area.

$$= I_{xx}$$

$$= \int_{-d/2}^{d/2} by^2 dy = b \cdot \frac{y^3}{3} \Big|_{-d/2}^{d/2}$$

$$= \frac{bd^3}{12}$$

Similarly it can be shown that $I_{yy} = \frac{db^3}{12}$

Let us consider a circle of radius r and an elementary ring of thickness dy at a distance of y from the centre 'O'.

Now area of this elemental ring = dA

$$= 2\pi y \cdot dy$$

M.I. of this ring about 'O' = $2\pi y \cdot dy \cdot y^2$

and M.I. of the entire area i.e. $I_{zz} = \int_0^r 2\pi y \cdot dy \cdot y^2$

$$= 2\pi \times \int_0^r y^3 dy$$

$$= 2\pi \times \frac{r^4}{4}$$

$$= \frac{\pi r^4}{2}$$

$$\therefore I_{xx} = I_{yy} = \frac{I_{zz}}{2}$$

$$= \frac{\pi r^4}{2} \times \frac{1}{2}$$

$$= \frac{\pi r^4}{4}$$

$$= \frac{\pi d^4}{64}$$

Moment of inertia of built up section :

The second moment of area of a built up section which consists of a number of simple sections can be found out as the sum of the second moments of area of the simple sections.

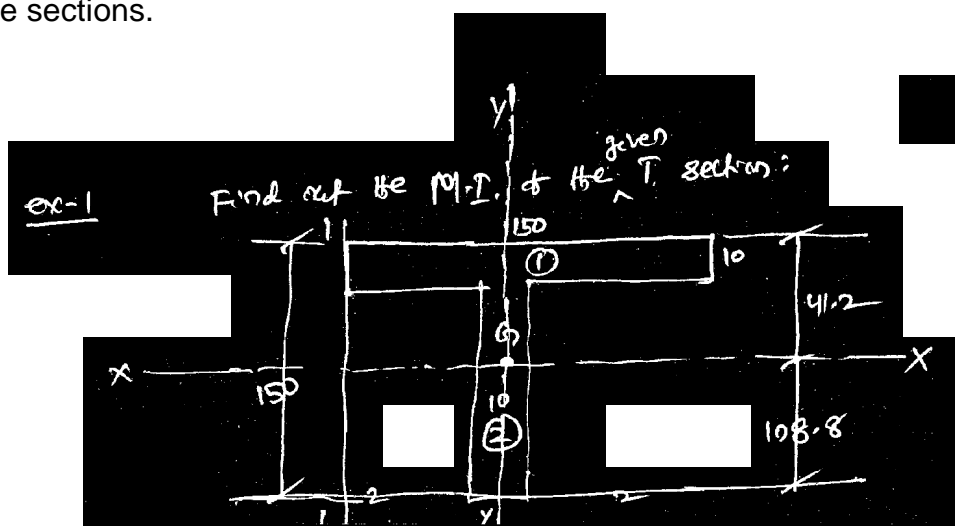

$$\bar{x} = 75\text{mm} \text{ (from the reference axis 1-1)}$$

$$\bar{y} = \frac{a_1 y_1 + a_2 y_2}{a_1 + a_2} \text{ (from the reference axis 2-2)}$$

$$= \frac{150 \times 10 \times 145 + 140 \times 10 \times 70}{150 \times 10 + 140 \times 10}$$

$$= \frac{217500 + 98000}{1500 + 1400}$$

$$= 108.8 \text{ mm}$$

Moment of inertia of the T section can be found out by adding the M.I. of the two simple rectangular sections.

M.I. of the 1st portion about the axis x-x

$$= \frac{150 \times 10^3}{12} + 150 \times 10 \times (41.2 - 5)^2$$

$$= 12,500 + 19,65,660$$

$$= 19,78,160$$

M.I. of the 2nd portion about the axis x-x

$$\frac{10 \times 140^3}{12} + 10 \times 40 \times (108.8 - 70)^2$$

$$= 22,86,666.7 + 21,07,616$$

$$= 43,94,282.7 \text{ mm}^4$$

∴ M.I. of the T section about xx - axis

$$I_{xx} = 1978160 + 4394282.7$$

$$= 63,72,442.7 \text{ mm}^4$$

SIMPLE MACHINES (ENGG. MECHANICS)

Chapter 5

Before going to details of Simple Machines, we should know the following terms and their definitions.

5.1. Important Terms :

1. Simple Machine :

It is a contrivance in which an external force is applied at some point in order to overcome a bigger resistance at some other point.

Example

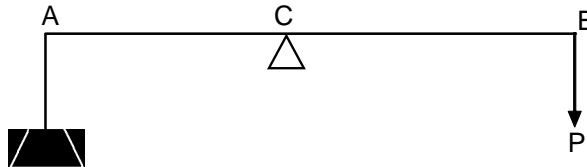

Taking moment about C, we get $W \times AC = P \times BC$

$BC > AC$

$$\frac{W}{P} = \frac{BC}{AC}$$

$W > P$ or $P < W$

W - resistance or load

P - external force or effort

2. Lifting Machine :

It is a Simple machine in which the load lifted acts as a resistance.

3. Mechanical Advantage :

Briefly known as M.A. is the ratio of the weight lifted to the effort applied.

$$M.A = \frac{W}{P}$$

No unit, it is a pure number.

4. Input of a Machine

The input of a machine is the work done on the machine.

In a lifting machine, it is measured by the product of the effort and the distance through which it has moved.

$$\boxed{\text{Input} = P \times Y} \text{ - N.M.}$$

Where P = Effort in N and Y = distance moved by effort in M.

5. Output of a Machine

In a lifting machine, it is measured by the product of the weight lifted and the distance through which it has been lifted.

$$\boxed{\text{Input} = W \times X} \text{ - N.M.}$$

Where W is load in N and X is distance in M which the load is lifted.

6. Efficiency of a Machine

It is the ratio of output to the input of a machine.

Mathematically, $\eta = \frac{\text{output}}{\text{Input}}$

$$\therefore \frac{W \times X}{P \times Y} = \frac{\left(\frac{W}{P}\right)}{\left(\frac{Y}{X}\right)} = \frac{M.A}{V.R}$$

7. Ideal Machine

If the efficiency is 100% i.e., output = Input, the machine is called as a perfect or an ideal machine.

8. Velocity Ratio (V.R)

It is the ratio of the distance moved by the effort (y) to the distance moved by the load (x).

$$\text{Mathematically, } V.R = \frac{Y}{X}$$

9. Effort lost in Friction

Let P_1 = effort required to lift the same load W under ideal condition the Effort lost in Friction.

$$P - P_1$$

In ideal case, input = output

$$P_1 \times Y = W \times X$$

$$P_1 \frac{WX}{Y} = \frac{W}{\left(\frac{Y}{X}\right)} = \frac{W}{V.R}$$

$$\text{Effort lost in Friction} = P - P_1$$

$$= P - \frac{W}{V.R}$$

10. Reversibility of a lifting Machine

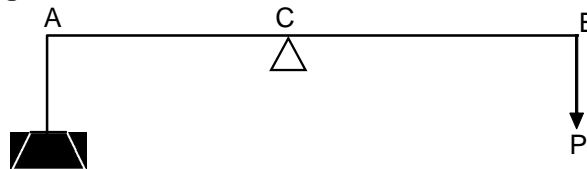

When the effort P is withdrawn the end A will go down wards raising the end B upwards. We say that the lever is reversible.

So a reversible machine is that machine in which the load moved in the reverse direction after withdrawal of the effort which was applied to raise the load.

$$\text{Work lost in Friction} = P \times Y - Wx$$

In order that, the load may fall back after withdrawal of the effort.

$$\text{So } W.X > P_y - Wx$$

$$\text{or } 2Wx > P_y$$

$$\text{or } \frac{Wx}{P_y} > \frac{1}{2}$$

$$\text{Efficiency} > \frac{1}{2} \text{ or Efficiency} > 50\%$$

Condition of Reversibility

The machine will be reversible when its efficiency is $> 50\%$

11. Self locking Machine

If a Machine is not capable of doing any work in the reverse direction after the effort is withdrawn and such a machine is called a non-reversible or self locking machine.

For this $\eta < 50\%$

12. Law of a lifting Machine

Where P = effort applied, W = load lifted, M and C are constants.

C - the effort required to move the machine under no load. i.e., to overcome friction.

13. Maximum Mechanical Advantage of a lifting Machine.

$$\text{we know, } M.A = \frac{W}{P}$$

$$\text{Also we know, } P = MW + C$$

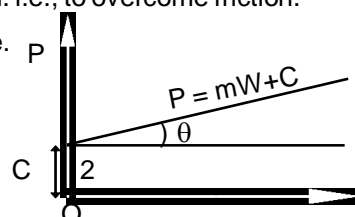

Then putting it

$$M.A = \frac{W}{MW + C} = \frac{1}{M + \frac{C}{W}}$$

neglecting $\frac{C}{W}$

$$(M.A)_{\max} = \frac{1}{M}$$

14. Maximum Efficiency of a lifting Machine

we know that

$$\eta = \frac{W/P}{VR} = \frac{W}{P \times VR}$$

Putting for max efficiency

$$\eta_{\max} = \frac{W}{(MW + C)VR} = \frac{1}{\left(M + \frac{C}{W}\right)VR}$$

$$\text{neglecting } \frac{C}{W}, \eta_{\max} = \frac{1}{M \times VR}$$

Example

In a lifting machine, an effort of 31 N raised a load of 1 KN. If efficiency of the machine is 0.75, what is its VR ? If on this machine, an effort of 61 N raised a load of 2 KN, what is now the efficiency ? what will be the effort required to raise a load of 5 KN ?

Solution

Data given $P_1 = 31 \text{ N}$, $W_1 = 1 \text{ KN} = 1000 \text{ N}$.

$\eta = 0.75$, $P_2 = 61 \text{ N}$, $W_2 = 2 \text{ KN} = 2000 \text{ N}$.

$\eta = ?$, $VR_1 = ?$, $P_3 = ?$, $W_3 = 5 \text{ KN} = 5000 \text{ N}$.

VR

$$\eta_1 = \frac{MA}{VR} = \frac{1000}{\frac{31}{VR}}$$

$$\text{or } 0.75 = \frac{1000}{31 \times VR}$$

$$\text{or } VR = \frac{1000}{31 \times 0.75} = 43 \text{ (Ans)}$$

η_2

$$\eta_2 = \frac{MA}{VR} = \frac{2000}{61 \times 43} = 0.763 \text{ or } 76.3\% \text{ (Ans)}$$

$P_3 = ?$

$$P = mW + c$$

$$31 = m \times 1000 + c \dots\dots (i)$$

$$61 = m \times 2000 + c \dots\dots (ii)$$

subtracting (i) from (ii)

$$61 - 31 = 2000m - 1000m$$

$$\Rightarrow 30 = 1000m$$

$$\Rightarrow m = \frac{30}{1000} = 0.03$$

We have $31 = 1000M + C$

$$31 = 1000 \times .03 + C$$

$$\Rightarrow 31 = 30 + C$$

$$\Rightarrow C = 1$$

Then $P = 0.03W + 1$

Now for 5000N, $P = 0.03 \times 5000 + 1$

$$\Rightarrow \boxed{P = 151 \text{ N}} \text{ (Ans)}$$

5.2. Study of Simple Machine

Types

1. Simple wheel and axle.
2. Differential wheel and axle.
3. Weston's differential pulley block.
4. General pulley block.
5. Worm and worm wheel.
6. Worm geared pulley block.
7. Single purchase crab winch.
8. Double purchase crab winch.
9. Pulleys :
 - (a) First system of Pulleys
 - (b) Second system of Pulleys
 - (c) Third system of Pulleys
10. Simple Screw Jack
11. Differential Screw Jack
12. Worm geared Screw Jack.

1. Simple wheel and Axle

In Fig 2.1 is shown a simple when and axle, in which the wheel A and axle B are keyed to the same shaft. A string is wound round the axle B, which carries the load W to be lifted. A Second string is wound round the wheel A in the opposite direction to that of the string on B.

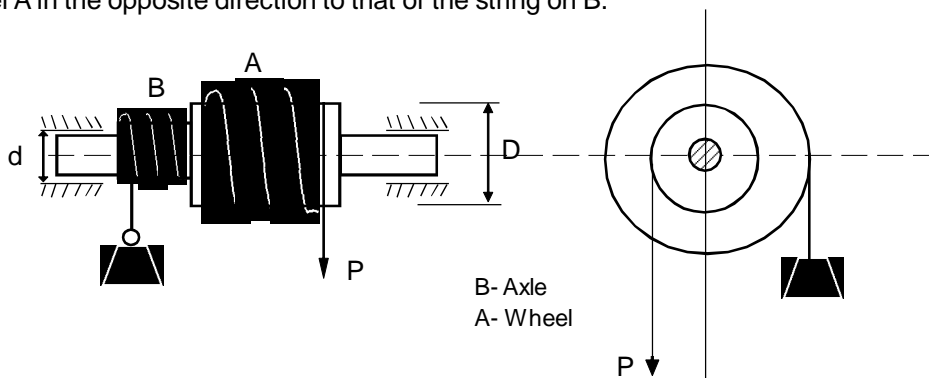

Fig 2.1 Simple wheel and axle

One end of the string is fixed to the wheel, while the other is free and the effort is applied to this end. Since th two strings are wound in opposite directions, therefore, a downward motion of P will raise the load W.

Let D = Diameter of effort wheel

d = Diameter of the load axle

w = Load lifted, and

p = Effort applied to the load.

Since the wheel as well as the axle are keyed to the same shaft, therefore when the wheel makes one revolution the axle will also make one revolution.

In one revolution of effort wheel A, displacement of effort similarly the load displacement = πD

$$VR = \frac{\pi D}{\pi d} \times \frac{D}{d}$$

$$MA = \frac{W}{P}$$

$$\eta = \frac{M.A}{VR}$$

If t_1 = thickness of the rope used over the wheel.

and t_2 = thickness of the rope used over the axle.

$$\text{then VR} = \frac{D + T_1}{d + T_2}$$

Example

In a wheel and axle machine, the diameter of the wheel is 100cm and that of the axle is 10 cm. The thickness of the load on the wheel is 3 mm and that on the drum is 6 mm. In this machine a load of 500 N is lifted as an effort of 100 N. Determine the efficiency and state whether the machine is reversible at this load.

Data given : $D = 100 \text{ cm}$, $W = 500 \text{ N}$

$d = 10 \text{ cm}$, $P = 100 \text{ N}$

$T_1 = 3 \text{ mm}$

$T_2 = 6 \text{ mm}$

To find, $n = ?$

$$\text{MA} = \frac{W}{P} = \frac{500}{100} = 5$$

Solution

$$\text{MA} = \text{VR} = \frac{D + t_1}{d + t_2}$$

$$\Rightarrow \text{VR} = \frac{(100 + 0.3) \text{ cm}}{(10 + 0.6) \text{ cm}} = 9.46$$

$$\text{and } \eta = \frac{\text{MA}}{\text{VR}} = \frac{5}{9.46} \times 100 = 52.85\% \text{ (Ans)}$$

Since efficiency is greater than 50%, the machine is reversible.

Double Purchase crab Double or Purchase winch

Diagram

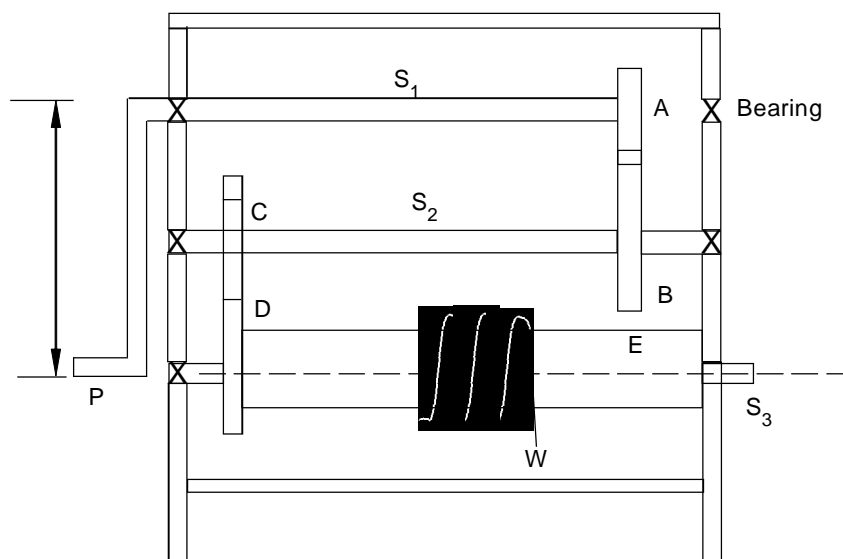

Fig.2.2 Single Purchase crab

Single purchase crab consists of a Pinion (A), which is engaged with a Spur gear B. Gear A and the effort handle are fixed to the same shaft (G_1). Also, adrum C and the gear b are fixed to the same shaft (S2). Load is lifted by a string wound round the drum.

Calculation

Let T_A = number of teeth of Pinion(A)

T_B = number of teeth of the gear (B)

L = Length of the effort handle

D = diameter of the load drum.

When the effort handle is rotated once, the distance moved by effort = $2\pi L$ when the handle is rotated once, the Pinion (A) also rotates once, i.e., $N_A = 1$ rpm, where N_A = revolution of Pinion A.

Let N_B = revolution of gear B

Then we know for gear Drive

$$\frac{N_B}{N_A} = \frac{T_A}{T_B}$$

$$\therefore N_A \times \frac{T_A}{T_B} = 1 \times \frac{T_A}{T_B} = \frac{T_A}{T_B}$$

Revolution of Pinion C is the same as that of gear (B) as both are connected to same shaft.

$$\text{So } N_C = \frac{T_A}{T_B}$$

Again we know,

$$\frac{N_D}{N_C} = \frac{T_C}{T_D}$$

$$\therefore N_D = N_C \times \frac{T_C}{T_D}$$

Putting N_C value

$$\Rightarrow N_D = \frac{T_A}{T_B} \times \frac{T_C}{T_D}$$

Super gear (D) and a drum (E) are mounted on a third shaft S_3 .

So when the effort handle makes one revolution, the gear D and drum E make $\frac{T_A T_C}{T_B T_D}$ revolution.

So, the load is lifted through a distance = $\pi D \times \frac{T_A T_C}{T_B T_D}$

Where D= diameter of the load drum E

$$\text{Hence Velocity Ratio} = \frac{2\pi \ell}{\pi D \times \frac{T_A T_C}{T_B T_D}}$$

$$\boxed{\text{VR} = \frac{2\ell}{D} \times \frac{T_B T_D}{T_A T_C}}$$

Example

In a double purchase crab, the pinions have 15 and 20 teeth while the spur wheels have 45 and 42 teeth. The effort handle is 40 cm. While the effective diameter of the drum is 15 cm, if the efficiency of the winch is 40%, what load will be lifted by an effort of 250N applied at the end of the handle ?

Data Given

$$T_A = 15, T_B = 45$$

$$T_C = 20, T_D = 40$$

$$L = 40 \text{ cm } D = 15 \text{ cm}$$

$$\eta = 40\%, P = 250 \text{ N}$$

To find $W = ?$

Solution

we know,

$$VR = \frac{2\ell}{D} \times \frac{T_B T_D}{T_A T_C}$$

$$\text{Or } VR = \frac{2 \times 40}{15} \times \frac{45 \times 40}{15 \times 20} = 32$$

$$\eta = \frac{M.A}{VR} = \frac{W / 250}{15}$$

$$\text{Or } 0.4 = \frac{W}{250 \times 32}$$

$$\Rightarrow W = 3200\text{N} = 32\text{KN (Ans)}$$

SINGLE PURCHASE CRAB WINCH

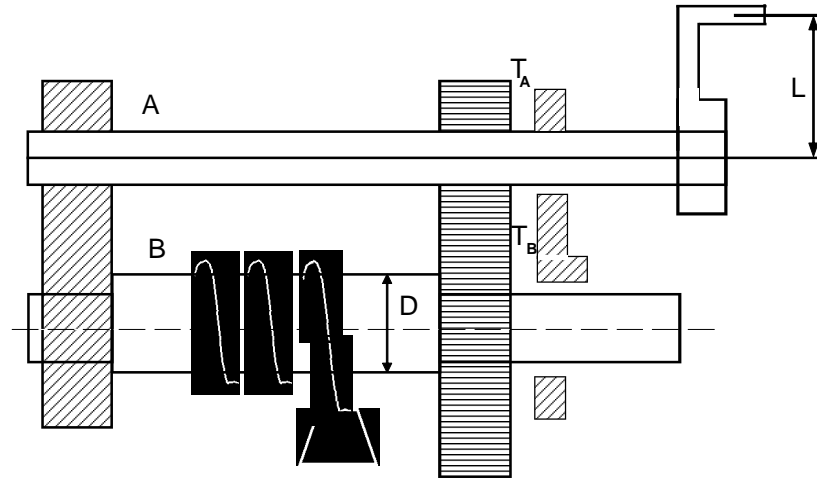

Fig 2:3 Single Purchase Crab Winch. In a Single Purchase Crab Winch, a rope is fixed to the drum and wound. A spur gear (B) is mounted on the load drum. Another pinion A is geared with (B) and connect to effort wheel.

$$\frac{N_B}{N_A} = \frac{T_A}{T_B}$$

If, $N_A = 1$

$$N_B = \frac{T_A}{T_B}$$

Distance moved by load in N_B revolution

$$= \pi D \times \frac{T_A}{T_B}$$

$$VR = \frac{y}{x} = \frac{2\pi\ell}{\pi D \times \frac{T_A}{T_B}} = \frac{2\ell}{D} \times \frac{T_B}{T_A}$$

Example

In a Single Purchase Crab, the number of Teeth on Pinion is 25 and on the Spur wheel 250, Radio of the drum and handle are 1500 mm and 300 mm respectively. Find the efficiency of the machine and the effect of friction, if an effort of 20 N can lift a load of 300 N.

Data given

$$T_A = 25$$

$$T_B = 250$$

$$D = 2 \times 150 = 300 \text{ mm} = 30 \text{ cm}$$

$$\ell = 300 \text{ mm} = 30 \text{ cm}$$

To Find, $\eta = ?$ and Friction = ?

Solution

$$VR = \frac{2\ell}{D} \times \frac{T_B}{T_A}$$

$$= \frac{2 \times 30}{30} \times \frac{250}{25} = 20$$

$$\eta = \frac{MA}{VR} = \frac{300/20}{20} = 75 = 75\% \text{ (Ans)}$$

$$\begin{aligned} \text{Effort lost in Friction} &= P - \frac{W}{VR} \\ &= 20 - \frac{300}{20} = 5 \text{ N (Ans)} \end{aligned}$$

Worm and Worm Wheel

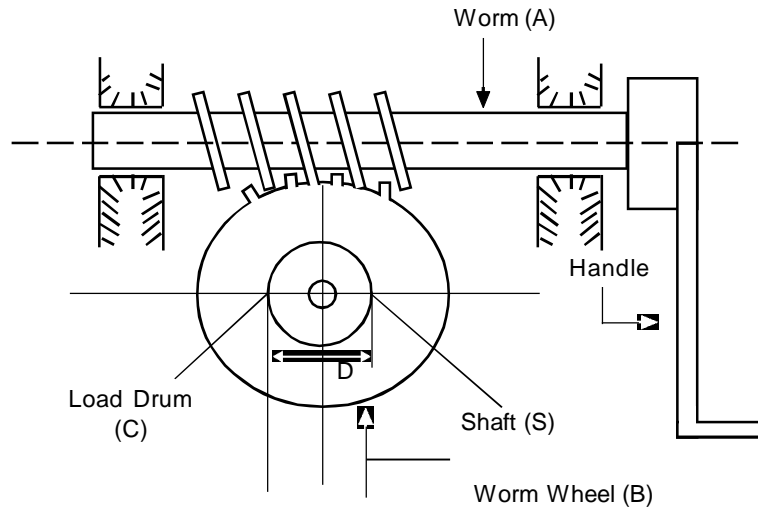

Description

Worm is threaded spindle (A)

Worm wheel is a spur gear (B)

The threads of the worm are engaged within the teeth of the worm wheel. A load drum (C) is mounted on the same shaft (S) as that of the worm wheel. A string hangs vertically from the load drum string hangs vertically from the load drum (C) and the load (W) to be lifted is attached to the string at its free end and as shown above. The effort (P) is applied at the end of a handle fitted at one end of the worm.

When the worm is rotated by application of effort at the end of the handle, the worm wheel and the drum (C) rotate winding the string round the surface of the drum. In this way the load is lifted the Worm(A) may have single start threads as 'multi start threads'.

If the worm has single start threads, in one rotation of the worm, one teeth.

If the worm has double start threads is one rotation of the worm, two teeth of the worm wheel will move, and so on.

Calculation of VR

Let ℓ = Length of the effort handle

n = no. of starts of the worm

$n = 1$, single start thread

$n = 2$, double start thread

T = number of teeth of the worm wheel.

D = Diameter of the load drum (C)

Considering on rotation of the effort handle, the distance through which effort (P) moves = $2\pi\ell$

We Know

$$\frac{N_A}{N_B} = \frac{T_B}{T_A}$$

$$\frac{N_B}{N_A} = \frac{T_A}{T_B}$$

If $N_A = 1$ rpm

$$\Rightarrow N_B = 1 \times \frac{T_A}{T_B} = \frac{T_A}{T_B}$$

Here for single start $T_A = 1$

$$\therefore N_B = \frac{1}{T_B} = \frac{1}{T}$$

In one rotation of the load drum the load is lifted to a height πD

In N_B rotation the load lifted will be $N_B \times \pi D = \pi D \times \frac{1}{T}$

In Multi start thread the load lifted will be = $\frac{\pi D \times n}{T}$

$$VR = \frac{2\pi L}{\pi D \times \frac{n}{T}} = \frac{2L}{D} \times \frac{T}{n}$$

$$\therefore VR = \frac{2LT}{nD}$$

Example

In a worm and worm wheel, the worm is triple threaded and the drum which is rigidly fixed to the wheel having common axis of rotation, has a diameter of 50 cm. Determine the number of teeth on wheel of 40 turns of the worm move the load up by 60 cm. If the handle attached to the worm has an effective length of 30 cm and the load lifted weighs 25 kN. Calculate the M.A. and take efficiency as 40 %.

Solution

Given $n = 3$, $D = 50$ cm, $L = 30$ cm, $W = 25$ kN, $\eta = 40\%$

In 40 turns of the worm, distance described by effort = $40 \times 2\pi \times 30 = 7539.83$ cm

$$\text{Hence } VR = \frac{7539.82}{60} = 125.66$$

$$\text{But } VR = \frac{2LT}{Dn} = \frac{2 \times 30}{50} \times \frac{T}{3}$$

$$\Rightarrow T = 314.15$$

As teeth can not be fraction, $T = 314$.

$$\frac{MA}{VR} = \eta$$

$$\frac{MA}{125.66} = 0.4$$

$$\Rightarrow MA = 50.264 \text{ (Ans)}$$

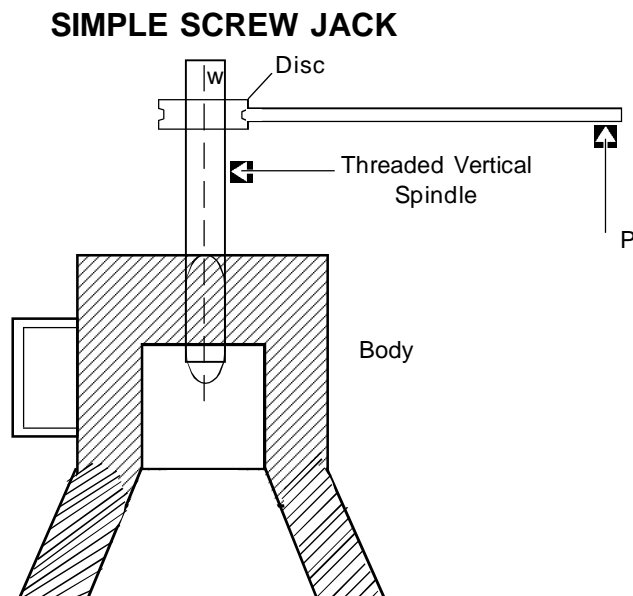

A Simple Screw Jack consists a vertical threaded spindle. The threaded portion of the spindle passes through a nut cut in the body of the Screw Jack.

The Load W is placed on a disc fitted at the top of the vertical spindle. The disc is fitted with a handle. Effort P is applied at the end of this handle. When the screw is turned by P , the screw either moves up or comes down through a nut, depending upon the direction of rotation of the handle.

A Screw Jack is used to raise and hold up heavy machinery like motor car, truck, etc.

Calculation

Let ℓ = Length of the lever

P = Pitch of the Screw

$$\text{Velocity Ratio} = \frac{2\pi\ell}{P}$$

Relation between Mean diameter Pitch and Helix angle of a Screw thread

$$D_m = \frac{D+d}{2}$$

Where D - outside diameter

d - Inside diameter

Threads of a Screw may be considered to be a metal strip wrapped round a cylinder in the form of helix.

The development of this helix in one pitch length is shown here.

$$\text{So } \tan \alpha = \frac{P}{\pi D_m}$$

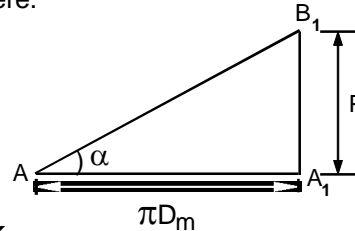
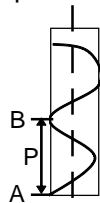

Effort Required to Lift a load by means of a Screw Jack

When a load is lifted by means of a Screw Jack the case becomes equivalent to lifting a load (W) up an inclined plane of inclination α by applying a horizontal force. The equivalent inclined plane.

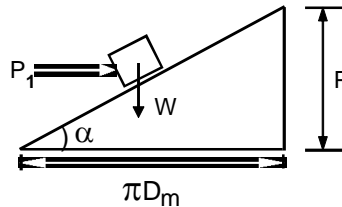

Let P_1 = horizontal force required to move a body of weight W up the inclined plane.

$$\text{Then } P_1 = W \tan(\alpha + \theta)$$

Where θ = Angle of Friction.

In case of Screw Jack, P_1 , acts at a distance of mean radius from the axis of the screw.

$$P \times \ell = P_1 \times \frac{D_m}{2}$$

$$= W \tan(\alpha + \theta) \times \frac{D_m}{2}$$

$$= W \times \frac{D_m}{2} \left(\frac{\tan \alpha + \tan \theta}{1 - \tan \alpha \times \tan \theta} \right)$$

$$= W \times \frac{D_m}{2} \left(\frac{\frac{P}{\pi D_m} + \mu}{1 - \frac{P}{\pi D_m} \times \mu} \right)$$

$$= W \times \frac{D_m}{2} \left(\frac{P + \mu \pi D_m}{\pi D_m - \mu P} \right)$$

$$\text{or } P = W \times \frac{D_m}{2\ell} \times \frac{P + \mu \pi D_m}{\pi D_m - \mu P}$$

Effort Required to Lower a load by Screw Jack

The Equivalent plane is shown below :

$$\text{Here } P \times \ell = P_1 \frac{D_m}{2} = W \tan(\theta - \alpha) \times \frac{D_m}{2}$$

$$\text{or } P = W \times \frac{D_m}{2\ell} = \frac{\mu \pi D_m - P}{\pi D_m - \mu P}$$

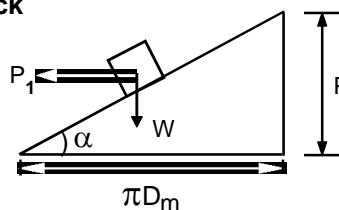

Efficiency when load is lifted

$$\eta = \frac{\text{output work}}{\text{Input work}} = \frac{W \times P}{P \times 2\pi\ell}$$

$$\text{Again } P \times \ell = P_1 \frac{D_m}{2}$$

DYNAMICS

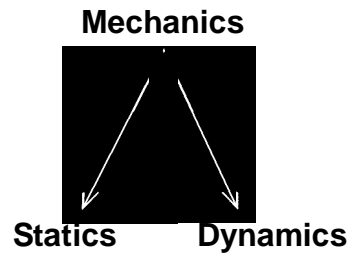

In contrast to statics, that deals with rigid bodies at rest, in dynamics we consider the bodies that are in motion. For convenience dynamics is divided into two branches called Kinematics and kinetics.

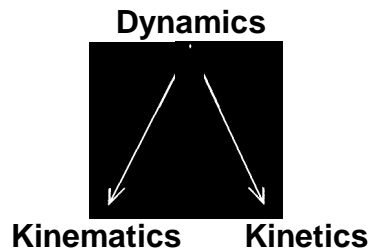

Kinematics :

kinematics is concerned with the space time relationship of given motion of a body without reference to the force that cause the motion.

Example : When a wheel rolls along a straight level track with uniform speed, the determination of the shape of the path described by a point on its rim and of the position along with path that the chosen point occupy at any given instant are problems of kinematics.

Kinetics : Kinetics is concerned with the motion of a body or system of bodies under the action of forces causing the motion.

Example : 1) When a constant horizontal force is applied to a body that rests on a smooth horizontal plane, the prediction of the way in which the body moves is a problem of kinetics.

2) Determination of the constant torque that must be applied to the shaft of a given rotor in order to bring it up to a desired speed of rotation in a given interval of time is a problem of kinetics.

Particle :

The whole science of dynamics is based on the natural laws governing motion of a particle or particles. A particle is defined as a material point without dimensions but containing a definite quantity of matter.

But in true sense of term there can be no such thing as a particle, since a definite amount of matter must occupy some space. However, when the size of a body is extremely small compared with its range of motion, it may in certain cases, be considered as a particle.

Example : 1) Star & planets, although many thousands of kilometers in diameter are as small compared with their range of motion that they may be considered as particles in space.

2) The dimensions of a rifle bullet are so small compared with those of its trajectory that ordinarily it may be considered as a particle.

Whenever a particle moves through space, it describes a trace that is called the path. Which may be either a space curve / tortuous path or a plane curve / plane path. In the simplest case when the plane path is a straight line the particle is said to have rectilinear motion or else, it is a curvilinear motion.

Displacement, velocity and acceleration function

These are the three quantities that are necessary to completely describe the motion of a particle in dynamics.

Displacement :

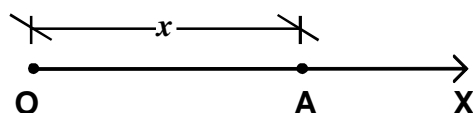

Assuming the motion of the particle along X-Axis, we can define the displacement of a particle by its x-coordinate, measured from the fixed reference point O. This displacement is considered as positive when the particle is to the right of the origin O and as negative when to the left.

As the particle moves, the displacement varies with time, and the motion of the particle is completely defined if we know the displacement x at any instant of time t . Analytically, this relation can be expressed by the general displacement – time equation, $x = f(t)$, where $f(t)$ stands for any function of time. This equation will take different forms depending upon how the particle moves along the x-axis. The displacement is measured by the unit of length.

Velocity :

In rectilinear motion, considering the case of uniform rectilinear motion, as represented graphically by the straight line BC, we see that for equal intervals of time Δt , the particle receives equal increments of displacement Δx . This velocity v of uniform motion is given by the equation $v = \Delta x / \Delta t$. this velocity is considered as positive if the displacement x is increasing with time and negative if it is decreasing with time.

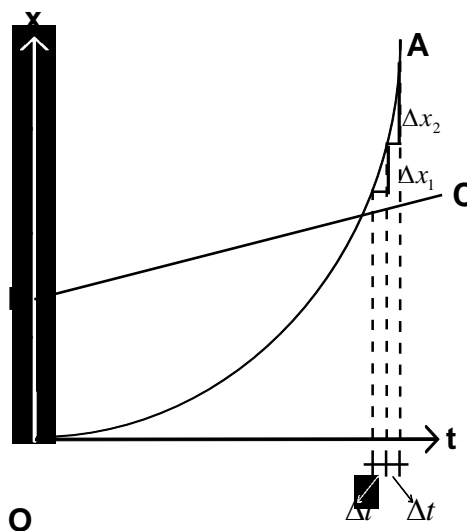

In the more general case of non-uniform rectilinear motion of a particle as represented graphically by the curve OA, in equal intervals of time Δt , the particle receives unequal increments of displacement. Δx_1 & Δx_2 , Thus, if Δx denotes the increment of displacement received during the interval of time Δt , the average velocity during this time is given by the equation $v_{av} = \Delta x / \Delta t$. As the time interval Δt is taken

smaller and smaller, the motion during the interval becomes more & more nearly uniform so that this ratio $\Delta x / \Delta t$ approaches more and more closely to the velocity at any particular instant of time interval. Taking the limit approach we obtain the instantaneous

$$\text{velocity of the particle } v = \lim_{\Delta t \rightarrow 0} \frac{\Delta x}{\Delta t} = \frac{dx}{dt} = \dot{x} .$$

Thus we see that the velocity time relationship of a moving particle can always be obtained by differentiating the displacement time equation. If the derivative is (+)ve i.e. the displacement increases with time, the velocity is positive and has a positive direction of the x-axis other wise it is negative. The velocity is measured by the unit of length divided by the unit of time.

Acceleration :

If the rectilinear motion of particle is non uniform its velocity is changing with time and we have acceleration. But in case of uniform motion, the velocity remains constant and there is zero acceleration. When the particle receives equal increments of velocity “v in equal intervals of time Δt , we have motion with constant acceleration as given by the equation $a = \frac{\Delta v}{\Delta t}$. Acceleration is consider positive when the velocity obtains positive increments in successive intervals of time and negative if the velocity is decreasing. However the acceleration of a particle may be positive when its velocity is negative of vice versa.

It the more general case when in equal intervals of time Δt , the increments of velocity Δv_1 and Δv_2 are unequal, we have a motion of the particle with variable acceleration. To obtain the acceleration of the particle at any instant t in such a case, we take the limit approach using the equation

$$a = \lim_{\Delta t \rightarrow 0} \frac{\Delta v}{\Delta t} = \frac{d^2x}{dt^2} = \ddot{x} .$$

Thus, in any case of rectilinear motion of a particle, the acceleration time relationship can be expressed analytically by taking second derivative with respective time of the displacement time equation. The acceleration is measured by the unit of length divided by square of unit of time.

Problem 1:

A slender bar AB of length l which remains always in the same vertical plane has its ends A & B constrained to remain in contact with a horizontal floor and a vertical wall respectively as shown in the figure. The bar starts from the vertical position and the end A is moving along the floor with constant velocity v_0 . So that its displacement $OA = v_0 t$. Write the displacement – time, velocity-time and acceleration-time equations for the vertical motion of the end B of the bar.

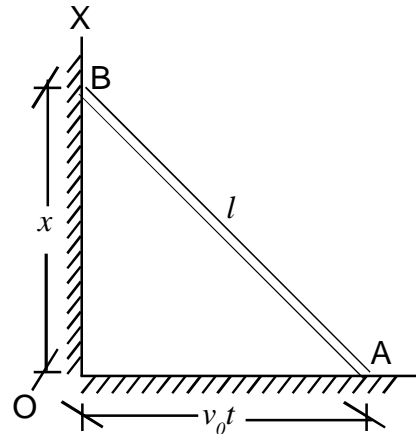

Solution :

Let us choose x-axis along the vertical line of motion of end B, i.e. along OB with origin at O.

From the geometrical relationship of the figure, the displacement x of the end b is given by the equation.

$$x = \sqrt{l^2 - (v_0 t)^2} \text{ ----- (1)}$$

which is the desired displacement time equation.

Differentiating w.r.t. time once, we get

$$\dot{x} = (-) \frac{v_0^2 t}{\sqrt{l^2 - v_0^2 t^2}} \text{ ----- (2)}$$

the velocity time equation.

Differentiating w.r.t. time twice, we get

$$\ddot{x} = (-) \frac{v_0^2 l^2}{(l^2 - v_0^2 t^2)^{3/2}} \text{ ----- (3)}$$

the acceleration time equation.

These expressions are valid in the interval $(0 < t < l/v_0)$

Problem 2 :

A particle starting from rest moves rectilinearly with constant acceleration a and acquires a velocity v in time t , traveling a total distance s . Develop formulae showing the relationship that must exist among any three of these quantities.

Solution :

Let us draw the velocity time diagram. Here

- i) The acceleration a is represented by the slope of the straight line OA.
- ii) The velocity v by the ordinate BA.
- iii) The time t by the abscissa OB.
- iv) The distance traveled s by the area OAB.

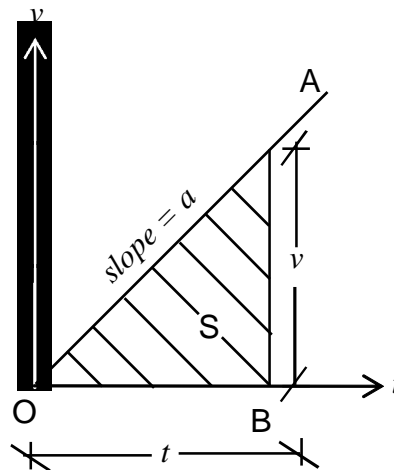

From geometry of the figure we may write $v = at$ ----- (1), $s = 1/2 vt$ ----- (2)
 Putting (1) in (2), $s = 1/2 at^2$ ----- (3)

Eliminating t from equations (1) & (2), $t = \frac{v}{a}$ & $s = \frac{1}{2} v \cdot \frac{v}{a}$ or $v = \sqrt{2as}$ ----- (4)

But these formulae do not account for any initial displacement or initial velocity.

Problem 3 :

A particle moving with initial velocity u moves with constant acceleration a and acquires a velocity v after time t during which it travels a total distance s . Develop formulae showing relationship between these four quantities. Also give the expression for displacement, if it has an initial displacement s_0 before it starts moving.

Solution :

Acceleration $a =$ slope of AB
 Initial velocity $u =$ OA along velocity axis.

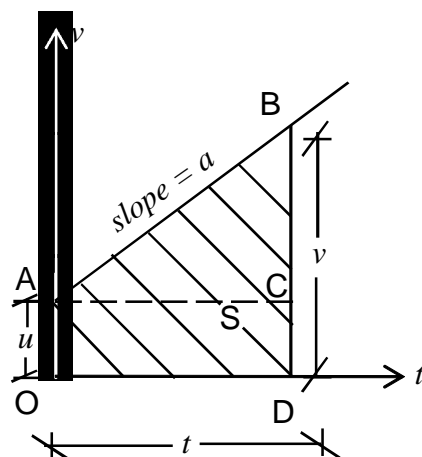

Velocity $v =$ ordinate BD

Time $t =$ ordinate OD

Distance $s =$ area of OABCD

From the geometry of the figure, we may write,

$$v = CD + CB = OA + CB = u + at \text{ ----- (1)}$$

$$s = \triangle ABC + \square OACD = ut + 1/2 at^2 \text{ ----- (2)}$$

$$\begin{aligned} \text{Eliminating } t, t = \frac{v-u}{a}, s &= u\left(\frac{v-u}{a}\right) + \frac{1}{2}a \times \left(\frac{v-u}{a}\right)^2 = \frac{uv-u^2}{a} + \frac{(v-u)^2}{2a} \\ &= \frac{2uv - 2u^2 + v^2 + u^2 - 2uv}{2a} = \frac{v^2 - u^2}{2a} \\ \text{or } v^2 - u^2 &= 2as \text{ ----- (3)} \end{aligned}$$

When there is initial displacement, $s = s_0 + ut + 1/2 at^2$.

Principles of dynamics

There are several axioms called the principle of dynamics which are concerned with the relationship between the kind of motion of a particle and the force producing it. These axioms are in fact, broad generalization of Kepler's observation on the motion of heavenly bodies and of carefully conducted experiment with the motion of earthly bodies. The first reliable experiments were made by Galileo in this connection who discovered the first two laws of motion of a particle. However, the complete set of principles and their final formulation were made by Newton after the name of which they are commonly called the Newton's laws of motion.

Newton's Laws of Motion :

First Law : This law also some times called the law of inertia is stated as "Every body continues in a state of rest or of uniform motion in a straight line unless and until it is acted upon by a force to change that state. For practical problems, we consider the surface of the earth as immovable and refer the motion of the particle with respect to the earth i.e. surface of the earth is taken as inertial frame of reference. But for the motion of heavenly bodies (planets & satellites), a system of coordinates defined by stars is taken as the immovable system of reference and their motion with respective these stars considered. From the first law it follows that any change in the motion of a particle is the effect of a force, that form the concept of force. However, the relation

between this change in velocity and the force that produces it given by the second law of dynamics.

Second Law :

The observations made by Galileo on the basis of his experiments on falling bodies and bodies moving along inclined planes, was verified by experiment on pendulums of various materials by Newton and generalized as second law of dynamics which states that the acceleration of a given particle / body is proportional to the force applied to it and acts in the direction of force.

In this law, as formulated above, there is no mention of the motion of the particle before it was acted upon by the force and hence the acceleration of a particle produced by a given force is independent of the motion of the particle. Thus a given force acting on particle produces the same acceleration regardless of whether the particle is at rest or in motion and also regardless of the direction of motion.

Again, there is no reference as to how many forces are acting on the particle. So if a system of concurrent forces is acting on the particle, then each force is expected to produce exactly the same acceleration as it would have if acting alone.

Thus, the resultant acceleration of a particle may be obtained as the vector sum of the accelerations produced separately by each of the forces acting upon it. Moreover, since the acceleration produced by each force is in the direction of the force and proportional to it, the resultant acceleration act in the direction of, and proportional to, the resultant force.

By using Newton's Second law, the general equation of motion of particle can be established as follows :

Let the gravity force i.e. weight of the particle W , acting alone produces an acceleration equal to g .

It instead of weight W , a force F acts on the same particle, then from the 2nd Law it follows that the acceleration a produced by this force will act the direction of the force and will be in the same ratio to the gravitational acceleration g as the force F to gravity force W .

$$\Rightarrow \frac{a}{g} = \frac{F}{W} \text{ or } \frac{W}{g} = \frac{F}{a} \text{ or } F = \frac{W}{g} a$$

This is the general equation of motion of a particle for which its acceleration at any instant can be obtained if the magnitude of force F is known. Also it is evident that for a given magnitude of force f , the acceleration produced is inversely proportional to the factor W/g , which is called mass of the particle denoted by m . This factor measures the degree of sluggishness (inherent resistance against motion) with which the particle yields (responds) to the action of applied force and is a measure of the inertia of the particle. Thus the second law of dynamics forms the basis of concept of mass. Thus using the notation $m = W/g$, the general equation of motion of a particle becomes $F=ma$.

Third Law :

By using the first two laws formulated above the motion of a single particle subjected to the action of given forces can be investigated. However in more complicated cases where it was required to deal with a system of particles or rigid bodies the mutual actions & reactions among them must be taken into account, which is given by Newton's third law. It states that "To every action there is always an equal and opposite reaction or in other words, the mutual action of any two bodies are always equal and oppositely directed".

This implies that if one body presses another, it is in turn is pressed by the other with an equal force in the opposite direction and if one body attracts another from a distance, this other attracts it with an equal and opposite force.

Example :

Sun attracts the earth with a certain force and therefore the earth attracts the sun with exactly the same force.

This holds good not only for the forces of gravitation but also for the other kind of forces such as magnetic or electrical forces. Thus a magnet attracts a piece of iron no more than the iron attracts the magnet.

The equation of motion can be used so solve two kinds of problems.

- 1) Motion of particle is given, to find the force necessary to produce such a motion.
- 2) The force is given and it is required to find the motion of the particle.

Let us discuss the first kind of problem :

Problem 4 :

A balloon of gross weight W falls vertically downward with constant acceleration a . What amount of ballast Q must be thrown out in order to give the balloon an equal upward acceleration a . Neglect air resistance.

Solution :

Case 1 : When the balloon is falling

The active forces on the balloon are :

- i) The total weight 'W' including the ballast, that acts vertically down ward and.
- ii) The buoyant force P , acting upward representing the weight of the volume of air displaced.

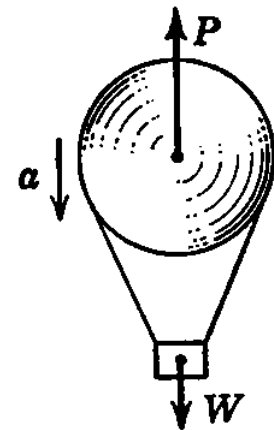

The equation of motion in this case may be written as

$$\frac{W}{g} a = W - P \text{ ----- (1)}$$

Case II : When the balloon is rising :

The active forces on the balloon are :

- i) The balance weight $(W-Q)$ excluding the ballast acting vertically downward.
- ii) The same buoyant force P acting upward as in the previous case.

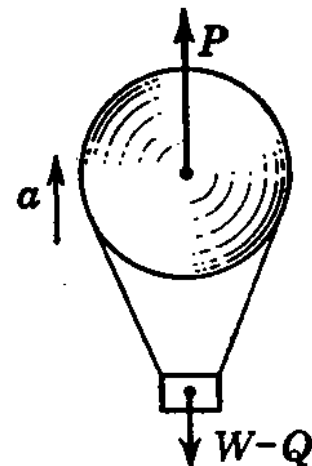

The equation of motion in this case may similarly be written as :

$$\frac{W}{g} a = P - (W - Q) \text{ ----- (2)}$$

Solving equations (1) & (2), we obtain

$$Q = \frac{2Wa}{g + a} \text{ ----- (3)}$$

Particular cases :

i) When $a=0$, if the balloon was in equilibrium, $Q=0$ & $W=P$
 \Rightarrow No ballast would have to be thrown out to rise with the same zero acceleration.

ii) When $a=g$, if the balloon was falling freely, $Q=W$ & $P=0$
 \Rightarrow It is impossible to throw out sufficient ballast to cause the balloon to rise.

Problem 5 :

Two equal weights W and a single weight Q are attached to the ends of the flexible but in extensible cord over hanging a pulley as shown in the figure. If the system moves with constant acceleration a as indicated by arrows, find the magnitude of the weight Q . Neglect air resistance and the inertia of the pulley.

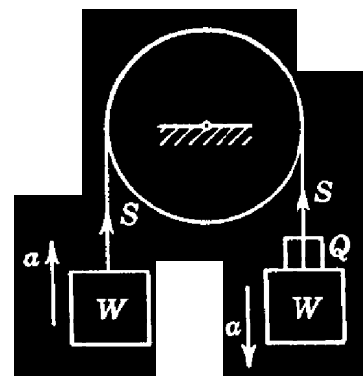

Solution :

Here we have a system of two particles for which there are two equations of motion.

For the weight on the left :

The active forces are the tension in the cord 'S' acting upward and the weight of the body 'W' down ward.

The equation of the motion in this case may be written as

$$\frac{W}{g}a = S - W \text{ ----- (1)}$$

For the weight on the right :

The active forces are the same tension in the cord 'S' acting upwards but a down ward force of $(W+Q)$.

The equation of motion in this case may similarly be written as :

$$\left(\frac{W+Q}{g}\right)a = (W+Q) - S \text{ ----- (2)}$$

Solving the equations (1) & (2), we have

$$Q = \frac{2Wa}{g - a} \text{ ----- (3)}$$

Particular Case : (Interpretation of the solution of the problem)

To produce an acceleration $a=g$ of the system would require a weight $Q = \infty$, which implies that it is impossible for the weight on the RHS to attain practically a free fall condition.

Motion of a particle acted upon by a constant force :

Now, let us discuss the second kind of dynamics problem, in which the acting force is given and the resulting motion of the particle is required. To start with, let us consider the simplest case of a particle acted upon by a constant force, the direction of which remains unchanged. In this case, the particle moves rectilinearly in the direction of force with a constant acceleration.

Let the line of motion be along x-axis and the magnitude of force be denoted by X. Also the particle starts from A with initial displacement x_0 , when $t = 0$.

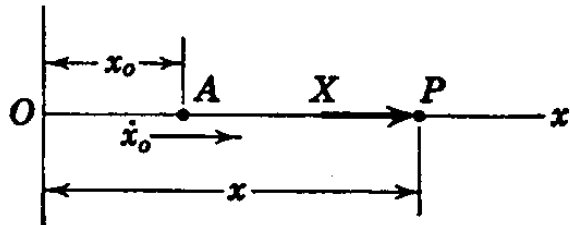

The equation of motion can be written as :

$$X = \frac{W}{g} a = \frac{W}{g} \ddot{x} \text{ or } \ddot{x} = \frac{X}{W/g} = a = \frac{d^2x}{dt^2} \text{ -----(1)}$$

To find the velocity \dot{x} and displacement x as function of time, integrating this differential equation,

we get, $d\left(\frac{dx}{dt}\right) = d(\dot{x}) = a dt$ or $\frac{dx}{dt} = \dot{x} = at + C_1$, where C_1 is the constant of integration.

Boundary condition :

At $t = 0$, $\dot{x} = \dot{x}_0 \Rightarrow C_1 = \dot{x}_0$

$\therefore \dot{x} = \dot{x}_0 + at$ -----(2)

This is the general velocity time equation for the rectilinear motion of a particle under the action of a constant force X.

Writing equation (2) in the form - $\frac{dx}{dt} = \dot{x} + at$ or $dx = \dot{x}_0 dt + at dt$ and integrating again,

we obtain, $x = \dot{x}_0 t + \frac{1}{2} at^2 + C_2$ -----(3)

Where C_2 again a constant of integration.

Boundary Condition :

At $t = 0$, $x = x_0 \Rightarrow C_2 = x_0$

$\therefore x = x_0 + \dot{x}_0 t + \frac{1}{2} at^2$

This is the general displacement time equation for the rectilinear motion of a particle under the action of a constant force X.

Thus the initial conditions influence the motion of a particle quite as much as does the acting force. Infact the initial condition represents the heredity of motion, while the acting force represents its environment.

Particular case :

Case – I – Freely falling body :

Acting force $X = W$ and $a = g$

Then from equations (2) & (3), $\dot{x} = \dot{x}_0 + gt$ ----- (2)'

$x = x_0 + \dot{x}_0 t + \frac{1}{2} gt^2$ -----(3)'

Case II – Body starts to fall from rest and from the origin :

In this case $x_0 = 0$ and $\dot{x}_0 = 0$ and the equations (2) & (3) reduces to

$\dot{x} = gt$ ----- (2)''

$x = \frac{1}{2} gt^2$ -----(3)''

Problem 6 :

A particle projected vertically upward is at a height h after t_1 seconds and again after t_2 seconds . Find the height h and also the initial velocity v_0 with which the particle was projected.

Solution :

Neglecting air resistance, the active force in the particle is its own gravity force W which is always directed vertically downward.

Taking x-axis along the vertical line of motion, the origin at the starting point and considering the upward displacement as positive, from displacement time equation we have :

$$\text{When } t = t_1, h = v_0 t_1 - \frac{1}{2} g t_1^2 \text{ -----(1)}$$

$$\text{\& When } t = t_2, h = v_0 t_2 - \frac{1}{2} g t_2^2 \text{ ----- (2)}$$

Multiply equation (1) with t_2 & equation (2) with t_1 & subtracting

$$h(t_2 - t_1) = \frac{1}{2} g t_1 t_2 (t_2 - t_1) \text{ or } h = \frac{1}{2} g t_1 t_2 \text{ ----- (3)}$$

$$\text{Equating equations (1) \& (2), } v_0 t_1 - \frac{1}{2} g t_1^2 = v_0 t_2 - \frac{1}{2} g t_2^2$$

$$\text{or } v_0 (t_1 - t_2) = \frac{1}{2} g (t_1 - t_2)(t_1 + t_2) \text{ or } v_0 = \frac{1}{2} g (t_1 + t_2) \text{ ----- (4)}$$

Problem 7 :

From the top of a tower of height $h = 40\text{m}$ a ball is dropped at the same instant that another is projected vertically upward from the ground with initial velocity $v_0 = 20 \text{ m/s}$. However from the top do they pass and with what relative velocity ?

Solution :

Case 1 : For the ball dropped from the top :

The top of the tower is taken as the origin and downward displacement is considered as positive. The initial displacement and initial velocity are zero. Acceleration due to its own gravitational force is downward. Thus the displacement time equation will be

$$x_1 = \frac{1}{2}gt^2 \text{ ----- (1)}$$

Case 2 : For the ball projected from the ground :

The ground is taken as the origin and the upward displacement is considered as positive. Here initial displacement = 0 and initial velocity = v_0 upward while the acceleration due to gravity is down ward. Thus the displacement time equation will be

$$x_2 = v_0t - \frac{1}{2}gt^2 \text{ ----- (2)}$$

When the balls pass each other, we must have

$$x_1 + x_2 = h \text{ ----- (3)}$$

Substituting the values of x_1 and x_2 from equation (1) & (2) in (3), we obtain,

$$\frac{1}{2}gt^2 + v_0t - \frac{1}{2}gt^2 = h \text{ or } h = v_0t \text{ -----(4)}$$

Putting numerical values, we have $t = \frac{v_0}{h} = \frac{40}{20} = 2 \text{ sec}$

Putting this value of t in equation (1) we find

$$(x_1)_{t=2} = \frac{1}{2} \times 9.81 \times 4 = 19.62m.$$

Relative Velocity :

The velocity time equation for case - I,

$$\dot{x}_1 = \frac{dx_1}{dt} = \frac{1}{2}g \cdot 2t = gt \quad \downarrow$$

At time t = 2 Sec, Velocity $\dot{x}_1 = 9.81 \times 2 = 19.62m/s \quad \downarrow$

The velocity time equation for case - II,

$$\dot{x}_2 = \frac{dx_2}{dt} = v_0 - gt \quad \uparrow$$

At time t = 2 Sec, Velocity $\dot{x}_2 = 20 - 19.62 = 0.38m/s \quad \uparrow$

∴ Their relative velocity $v_R = \dot{x}_1 - \dot{x}_2 = 19.62 - (-0.38) = 20m/s$

Hence the balls pass 19.62 m. below the top of the tower with a relative velocity of 20 m/s. i.e. same as the initial velocity.

Problem 8 :

A small block of weight W is placed on an inclined plane as shown in the figure. What time interval t will be required for the block to traverse the distance AB , if it is released from rest at A and the coefficient of kinetic friction on the plane is $\mu=0.3$. What is the velocity at B .

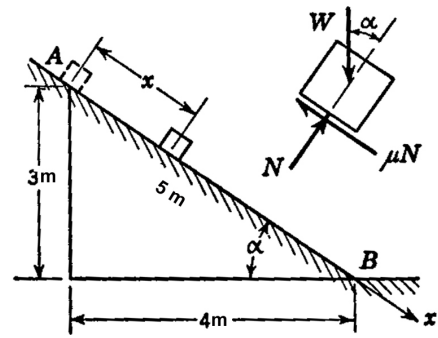
**Solution :**

From the free body diagram of the block, the resultant force along the plane $X = W(\sin \alpha - \mu \cos \alpha)$ acting down ward.

Resulting acceleration $a = \frac{X}{W/g} = g(\sin \alpha - \mu \cos \alpha)$

For sliding of the block, a must be positive $\Rightarrow (\sin \alpha - \mu \cos \alpha) > 0$ or $\tan \alpha \geq \mu$

Here $\sin \alpha = \frac{3}{5}$ and $\cos \alpha = \frac{4}{5}$ & putting other numerical values

$$a = 9.81 \left(\frac{3}{5} - 0.3 \times \frac{4}{5} \right) = 3.53 \text{ m/s}^2$$

Again the initial displacement = 0 and initial velocity = 0

The displacement time equation becomes $x = 0 + \frac{1}{2}at^2 = \frac{1}{2}at^2$

Putting numerical values $50 = \frac{1}{2} \times 3.53 \times t^2$ or $t^2 = 28.32$ or $t = 5.32 \text{ s}$

Substituting the value of t in the velocity time equation,

Velocity at B , $\dot{x}_b = 0 + at = at = 3.53 \times 5.32 = 18.78 \text{ m/s}$

D' Alembert's Principle :

The differential equation of rectilinear motion of a particle $X = m\ddot{x}$ can be written in the form $X - m\ddot{x} = 0$, where x denotes the resultant in the direction of X-axis of all applied forces and m , the mass of the particle.

This equation of motion of particle is of the same form as an equation of static equilibrium and may be considered as an equation of dynamic equilibrium. For writing this equation, we need only to consider in addition to the real forces acting on the

particle, an imaginary force $-m\ddot{x}$. This force equal to the product of the mass of the particle and its acceleration and directed oppositely to the acceleration, is called inertia force of the particle.

D' Alembert was first to point out this fact that equation of motion could be written as equilibrium equations simply by introducing inertia forces in addition to the real forces acting on a system. This idea is known as the D' Alembert's principles and has definite advantage in the solution of engineering problems of dynamics.

Due to application of this principle, when dealing with a system having one degree of freedom, we need to write only one equation of dynamic equilibrium in stead of writing as many equation of motion as there are particles. It particularly becomes very useful when used in conjunction with the method of virtual work.

Problem 9 : Two unequal weights W_1 and W_2 are attached to the ends of a flexible but inextensible cord overhanging a pulley as shown in the figure ($W_1 > W_2$). Neglecting air resistance and inertia of the pulley, find the magnitude of acceleration of the weights.

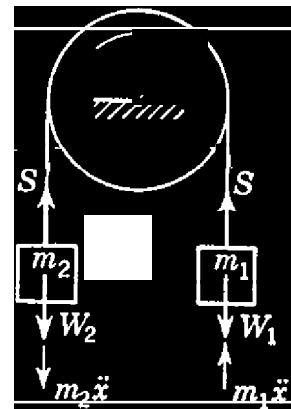

Solution :

Here we have a system of particle connected between themselves and so constrained that each particle can have only a rectilinear motion.

Assuming motion of the system in the direction shown by the arrow on the pulley, there will be upward acceleration \ddot{x} of the weight W_2 and downward acceleration \ddot{x} of the weight W_1 . Denoting the masses by m_1 and m_2 respectively, the corresponding inertia forces act as shown in the figure. Assuming the tension in the string (String Reaction) to be S on both sides of the pulley, neglecting friction on the pulley, we can have a system of forces in equilibrium for each particle by adding the inertia forces to the real forces.

$$S - W_2 - m_2\ddot{x} = 0 \text{ ----- (1)}$$

$$W_1 - S - m_1\ddot{x} = 0 \text{ ----- (2)}$$

Eliminating S from these equations, $W_2 + m_2\ddot{x} = W_1 + m_1\ddot{x}$ ----- (3)

Again this problem can be conceived in another way i.e. since each particle is in equilibrium we can say that the entire system of forces is in equilibrium. So instead of writing separate equations of equilibrium for each particle, we can write one equation equilibrium for the entire system by equating to zero the algebraic sum of moment of all the forces (including the inertia forces) with respect of the axis of the pulley.

In this case, we need not consider the internal forces or reaction S of the system and can directly write.

$$(W_2 + m_2\ddot{x})r = (W_1 - m_1\ddot{x})r \text{ or } W_2 + m_2\ddot{x} = W_1 - m_1\ddot{x}$$

from which
$$\ddot{x} = \left(\frac{W_1 - W_2}{W_1 + W_2} \right) g = \left(\frac{m_1 - m_2}{m_1 + m_2} \right) g$$

Problem 10 :

Let us solve the previous problem No. 5 by D' Alembert's Principle.

Solution :

Here also we have a system of two particles so connected that it has single degree of freedom.

Taking moment about the centre of the pulley O,

we have
$$\left(W + \frac{W}{g}a \right) r = \left\{ (W + Q) - \frac{(W + Q)}{g}a \right\} r$$

or
$$W + \frac{W}{g}a = (W + Q) - \frac{(W + Q)}{g}a$$

or
$$\frac{W}{g}a = Q - \frac{Wa}{g} - \frac{Qa}{g} \text{ or } \frac{2Wa}{g} = Q \left(1 - \frac{a}{g} \right)$$

or
$$\frac{2Wa}{g} = Q \left(\frac{g - a}{g} \right) \text{ or } Q = 2 \frac{Wa}{(g - a)}$$

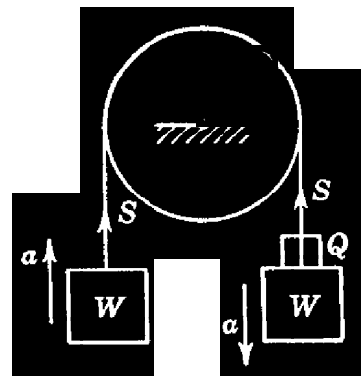

Problem 11 :

Two bodies of weight W_1 & W_2 are connected by a thread and move along a rough horizontal plane under the action of a force F applied to the first body. If the coefficient of friction between the sliding surface of bodies and the plane is 0.3, determine the acceleration of the bodies and tension in the thread.

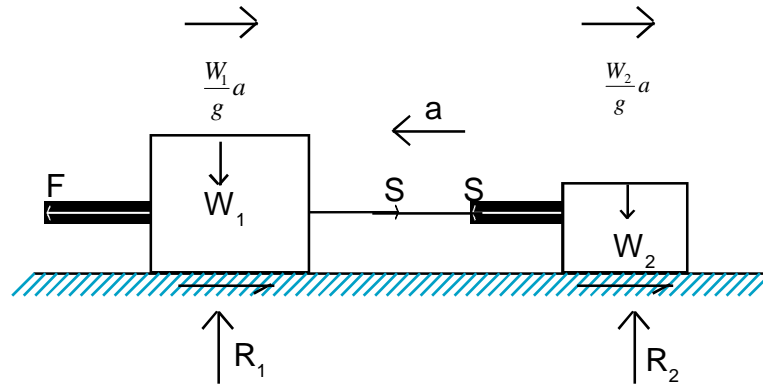

Given $m_1 = 80 \text{ Kg.}$, $m_2 = 20 \text{ Kg.}$, $\mu = 0.3$, $F = 400 \text{ N}$.

Solution :

Here also we have a system of two particles so connected that, it has a single degree of freedom. So we can apply D' Alembert's principle to the system and write only one equation of equilibrium for the entire system taking only the active forces but without considering the internal forces (reactions).

$$\begin{aligned} \text{Along horizontal direction, } F &= \frac{W_1}{g}a + \frac{W_2}{g}a + \mu W_1 + \mu W_2 \\ &= \left(\frac{W_1 + W_2}{g} \right) a + \mu(W_1 + W_2) \end{aligned}$$

$$\text{or, } \left(\frac{W_1 + W_2}{g} \right) a = F - \mu(W_1 + W_2)$$

$$\text{or, } a = \frac{F - \mu(W_1 + W_2)}{\left(\frac{W_1 + W_2}{g} \right)} \quad \text{or, } a = \frac{F - \mu g(m_1 + m_2)}{(m_1 + m_2)} = \frac{400 - 0.3 \times 9.81(80 + 20)}{(80 + 20)} = 1.06 \text{ m/s}^2$$

Considering the equilibrium of second body

$$S = \frac{W_2}{g}a + \mu W_2 = W_2 \left(\frac{a}{g} + \mu \right) = m_2(a + \mu g) = 20(1.06 + 0.3 \times 9.81) = 80 \text{ N}$$

** ** **

6.2 Work, Energy and Power

Work: When a force is acting on a body and the body undergoes a displacement then some work is said to be done. Thus the work done by a force on a moving body is defined as *the product of the force and the distance moved in the direction of the force.*

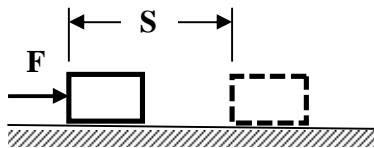

Body moving with direction of force

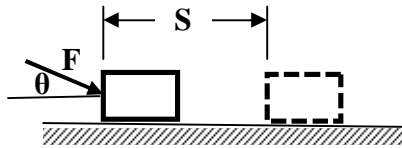

Body not moving with direction of force

When force F acts on the body and body displaces in the direction of force as shown in fig. The work done by the force $F = \text{Force} \times \text{Distance} = F \times S$

When the force acts on the body at an angle θ to the horizontal and the body moves in horizontal direction by distance s , then work done by the force $F = \text{Component of the force in the direction of displacement} \times \text{distance} = F \cos \theta \times S$.

From definition of work it is obvious that unit of work is obtained by multiplying unit of force by unit of length. Hence, if unit of force is newton and unit of distance is meter then unit of work is N.m. So one N-m of work is denoted by one Joule(J). Hence one joule may be defined as *the amount of work done by one newton force when the particle moves one meter in the direction of the force.*

Energy: Energy is defined as the capacity to do work. There are many forms of energy like heat energy, mechanical energy, electrical energy, and chemical energy. In mechanics mostly discussed about mechanical energy. The mechanical energy may be classified into two forms i.e Potential energy and Kinetic energy.

Potential Energy is the capacity to do work due to position of the body. A body of weight 'W' held at a height 'h' possesses an energy Wh .

Kinetic Energy is the capacity to do work due to motion of the body. Consider a car moving with a velocity v m/s. If the engine is stopped, it still moves forward doing work against frictional resistance and stops at a certain distance s .

From the kinematic of the motion, $0 - u^2 = 2as$

$$a = -\frac{u^2}{2s}$$

From D'Alembert's principle, $F + \frac{W}{g}a = 0$

$$F - \frac{W}{g} \times \frac{u^2}{2s} = 0$$

$$F = \frac{Wu^2}{2gs}$$

Then, Work done = $F \times s = \frac{Wu^2}{2g}$

This work is done by the energy stored initially in the body.

$$\text{Kinetic Energy} = \frac{1}{2} \times \frac{W}{g} v^2 = \frac{1}{2} m v^2$$

Where, m is the mass of the body and v is the velocity of the body.

Unit of energy is same as that of work, since it is nothing but capacity to do work. It is measured in joule (N-m) or kilo Joule (kN-m).

Power: It is defined as the time rate of doing work. Unit of power is watt (w) and is defined as one joule of work done in one second. In practice kilowatt is the commonly used unit which is equal to 1000 watts.

Work Energy equation: Consider the body shown in figure below subjected to a system of forces $F_1, F_2 \dots$ and moving with acceleration a in x-direction. Let its initial velocity at A be u and final velocity when it moves distance $AB=s$ be v . Then the resultant of system of the forces must be in x- direction. Let $F = \sum X$

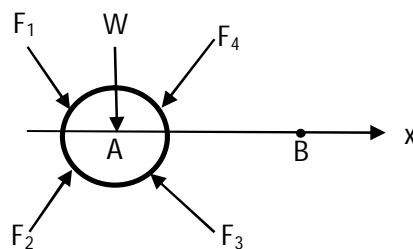

From Newton's second law, $F = \frac{W}{g}a$

Multiplying both side of the equation by elementary distance ds , then

$$Fds = \frac{W}{g} a ds = \frac{W}{g} \frac{dv}{dt} ds = \frac{W}{g} dv \frac{ds}{dt}$$

$$Fds = \frac{W}{g} v dv$$

Integrating both sides for the motion from A to B,

$$\int_0^s F ds = \int_u^v \frac{W}{g} v dv$$

$$Fs = \frac{W}{g} \left[\frac{v^2}{2} \right]_u^v = \frac{W}{2g} (v^2 - u^2)$$

Work done = Final kinetic energy- Initial kinetic energy (It is called work energy equation)

This work energy principle may be stated as *the work done by system of forces acting on a body during a displacement is equal to the change in kinetic energy of the body during the same displacement.*

Conservation of Energy:

Conservative force: A force is said to be conservative if the work done by the force on a system that moves between two configurations is independent of the path of the system takes.

Non-Conservative forces: A force is said to be non-conservative if the work done by a force on a system depends on the path of the system follows.

Principle of conservation of energy, “ when a rigid body or a system of rigid bodies, moves under the action of the conservative forces, the sum of the kinetic energy (T) and the potential energy (V) of the system remains constant.

$$T + V = \text{constant} \text{ or } \Delta T + \Delta V = 0 \text{ or } T_1 + V_1 = T_2 + V_2$$

Consider a conservative system; say a particle moving from position 1 to position 2.

As the particle moves from position 1 to position 2 it undergoes a change in potential energy,

$$\Delta V = V_2 - V_1$$

Where: V_1 and V_2 are the potential energies in positions 1 and 2 respectively.

As the particle displace from position 1 to 2, let U_{1-2} be the work of the forces that act on the particle. The work U_{1-2} does not depend on the path or the speed with which the particle moves on the path.

$$\text{Consequently, } U_{1-2} = V_1 - V_2 = -\Delta V$$

Then, the principle of work energy ($U_{1-2} = \Delta T$), yields $-\Delta V = \Delta T$

Where; $\Delta T = T_2 - T_1$ is change in kinetic energy from position 1 to position 2.

Thus relationship may be written as $\Delta T + \Delta V = 0$

$$T + V = \text{constant}$$

Where $T + V$ is called the mechanical energy of the particle.

6.3 Define Momentum & Impulse, Explain Conservation of energy and Linear momentum, Explain collision of elastic bodies and different co-efficient of restitution.

Solved Examples:

Example-1: A pump lifts 40m^3 of water to a height of 50m and delivers and delivers it with a velocity of 5m/sec. What is the amount of energy spent during the process? If the job is done in half an hour , what is the input power of the pump which has an overall efficiency of 70%?

Solution:Output energy of the pump is spent in lifting 40m^3 of water to a height of 50m and deliver it with the given kinetic energy of delivery.

Work done in lifting 40m^3 water to a height of 50m = Wh

Where W=weight of 40m^3 of water= 40×9810 N

(Note: 1m^3 of water weighs 9810 Newton)

Work done= Wh = $40 \times 9810 \times 50 = 19620000\text{Nm}$

$$\text{Kinetic energy at delivery} = \frac{1}{2} \times \frac{W}{g} \times v^2 = \frac{1}{2} \times \frac{40 \times 9810}{9.81} \times 5^2 = 500000\text{Nm}$$

Total Energy spent= $19620000 + 500000 = 20120000\text{Nm} = 20120\text{kNm} = 20.12 \times 10^6 \text{ Nm}$.

This energy is spent by the pump in half an hour i.e. in $30 \times 60 = 1800\text{sec}$.

$$\text{Output power of pump} = \text{Output energy spent per second} = \frac{20120000}{1800} = 11177.8\text{watts} = 11.1778\text{kW}.$$

$$\text{Input power} = \frac{\text{Output power}}{\text{efficiency}} = \frac{11.1778}{0.7} = 15.9583\text{kW}.$$

Example 2:For the same kinetic energy of a body, what should be the change in its velocity if its mass is increased four times?

Answer: Let 'm₁' be the mass of a body moving with a velocity 'v₁'.

$$\text{Kinetic energy } T_1 = \frac{1}{2} m_1 v_1^2$$

When mass is increased four times let the velocity be v₂.

$$m_2 = 4m_1$$

$$v_2 = ?$$

$$\therefore T_2 = \frac{1}{2} m_2 v_2^2$$

Substitute the value of m₂ in the above equation

$$T_2 = \frac{1}{2} 4m_1 v_2^2$$

Given

$$T_1 = T_2$$

$$\frac{1}{2} m_1 v_1^2 = \frac{1}{2} 4m_1 v_2^2$$

$$v_1^2 = 4v_2^2$$

$$v_2^2 = \frac{v_1^2}{4}$$

$$v_2 = \sqrt{\frac{v_1^2}{4}}$$

$$v_2 = \frac{v_1}{2}$$

The velocity of the body is halved when its mass is increased four times.

Example 3: Calculate the time taken by a water pump of power 500 W to lift 2000 kg of water to a tank, which is at a height of 15 m from the ground?

Solution: Given g = 10 m/s²

Power of the water pump = 500 W

$$P = \frac{W}{t}$$

Since the water is lifted through a height of 15 m, work done is equal to the potential energy.

$$\therefore P = \frac{mgh}{t}$$

Mass of water (m) = 2000 kg

$$g = 10 \text{ m/s}^2$$

Height (h) = 15 m

$$t = ?$$

$$t = \frac{mgh}{P}$$

$$t = \frac{2000 \times 10 \times 15}{500}$$

$$t = \frac{20 \times 10 \times 15}{5}$$

$$t = 40 \times 15 = 600 \text{ s}$$

Time required to lift water = 600 s.

Example 4: A car weighing 1000 kg and travelling at 30 m/s stops at a distance of 50 m decelerating uniformly. What is the force exerted on it by the brakes? What is the work done by the brakes?

solution: Mass of the car (m) = 1000 kg

Initial velocity (u) = 30 m/s

Distance traveled (S) = 50 m

Since the car stops, final velocity (v) = 0

Work done by the brakes = kinetic energy of the car

$$W = \frac{1}{2} m v^2$$

$$= \frac{1}{2} \times 1000 \times (30)^2$$

$$= 500 \times 900$$

$$= 450000 \text{ J}$$

$$W = F \times S$$

$$F = \frac{W}{S}$$

$$= \frac{450000}{50}$$

$$= 9000 \text{ N}$$

The force exerted by the brakes is 9000 N.

6.3 Momentum and Impulse

It is clear from the discussion of the previous chapters that for solving kinetic problems, involving force and acceleration, D'Alembert's principle is useful and that for problems involving force, velocity and displacement the work energy method is useful. The Impulse-Momentum method is useful for solving the problems involving force, time and velocity.

Momentum: Momentum is the motion contained in a moving body. It is also defined as the product of an object's mass and velocity. It is a vector.

The SI units of momentum are $\text{kg} \cdot \text{m/s}$.

Impulse: Impulse is defined as a force multiplied by the amount of time it acts over. In calculus terms, the impulse can be calculated as the integral of force with respect to time. Alternately, impulse can be calculated as the difference in momentum between two given instances.

The SI units of impulse are $\text{N} \cdot \text{s}$ or $\text{kg} \cdot \text{m/s}$.

Impulse-Momentum Equation: As stated earlier impulse can be calculated as the difference in momentum between two given instances.

If F is the resultant force acting on a body of mass m in the direction of motion of the body, then according to Newton's 2nd law of motion,

$$F = ma$$

But, acceleration, $a = \frac{dv}{dt}$, v is velocity of body.

$$\text{Then, } F = m \frac{dv}{dt}$$

$$\text{i.e. } F dt = m dv$$

$$\int F dt = \int m dv$$

If initial velocity is u and after time interval t the velocity becomes v , then

$$\int_0^t F dt = \int_u^v m dv$$

$$\int_0^t F dt = m[v]_u^v = mv - mu = \text{Impulse Momentum Equation}$$

The term $\int_0^t F dt$ is called the *impulse*. If the resultant force is in newton and time in second, the unit of impulse is N*sec.

If the resultant force F is constant during time interval t then, impulse is equal to $F \times t$.

The term $[mv - mu]$ is called change in momentum.

So, Impulse= Change in momentum= Final momentum- Initial momentum.

Impulse momentum equation can be stated as: *The component of the impulse along any direction is equal to change in the component of momentum in that direction.*

Note: Since the velocity is a vector, impulse is also a vector. The impulse momentum equation holds good when the direction of F , u and v are the same.

The impulse momentum equation can be applied in any convenient direction and the kinetic problem involving force, velocity and time can be solved.

Conservation of Linear Momentum:

The impulse momentum equation is: $\int_0^t F dt = mv - mu$

If the resultant force F is zero the equation reduces to $mv = mu$ i.e. Final Momentum = Initial Momentum, Such situation arises in many cases because the force system consists of only action and reaction on the elements of the system. The resultant force is zero, only when entire system is considered.

The principle of conservation of momentum may be defined as: *the momentum is conserved in a system in which resultant force is zero. In other words, in a system if resultant force is equal to zero, the initial momentum is equal to final momentum i.e. momentum is conserved.*

Example: When a person jumps off a boat, the action of the person is equal and opposite to reaction of boat. Hence the resultant force of system is zero. If w_1 is weight of the person and w_2 is weight of the boat, v is velocity of the person and the boat before the person jumps out of the boat and v_1, v_2 are the velocities of the person and the boat after jumping. According to conservation of momentum:

$$\frac{w_1 + w_2}{g} v = \frac{w_1}{g} v_1 + \frac{w_2}{g} v_2$$

Similar, equation also holds good when the system of a shell and gun is considered.

Note: It must be noted that conservation of momentum applies to entire system and not to individual elements of the system.

Collision: Collision is a dynamic event consisting of the close approach of two or more bodies resulting in an abrupt change of momentum and exchange of energy.

- A collision between two bodies is said to be impact, if the bodies are in contact for a short interval of time and exerts very large force on each other during this short period.
- On impact, the bodies deform first and then recover due to elastic properties and start moving with different velocities.
- The velocities with which they separate depend not only on their velocities of approach but also on the shape, size, elastic properties and line of impact.

Types of Impact:

According to Motion of Bodies:

- (a) **Direct impact:** If the motion of two colliding bodies is directed along the line of impact (common normal to the colliding surfaces), the impact is said to be direct impact.
- (b) **Indirect or Oblique impact:** If the motion of the one or both of the colliding bodies is not directed along the line of impact, the impact is known as oblique impact.

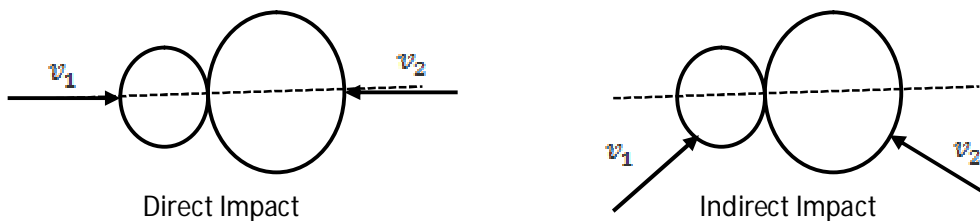

According to properties of bodies:

- (a) **Plastic impact:** The material properties of the colliding bodies are plastic or inelastic like putty, so the plastic deformation takes place at point of contact and both bodies move as a single body after impact. In this case only the principle of conservation of momentum hold good.

$$m_1 u_1 + m_2 u_2 = (m_1 + m_2) v$$

- (b) **Elastic collision:** The material properties of the colliding bodies are perfectly elastic, so the bodies regain its original shape after impact at the point of contact. In this case both the principle of conservation of momentum and energy hold good.

For conservation of momentum:

$$m_1 u_1 + m_2 u_2 = m_1 v_1 + m_2 v_2$$

$$m_1 (u_1 - v_1) = m_2 (v_2 - u_2)$$

For conservation of energy:

$$m_1 \frac{u_1^2}{2} + m_2 \frac{u_2^2}{2} = m_1 \frac{v_1^2}{2} + m_2 \frac{v_2^2}{2}$$

$$m_1 (u_1^2 - v_1^2) = m_2 (v_2^2 - u_2^2)$$

From above two equation, we get $u_1 + v_1 = u_2 + v_2$

$$u_1 - u_2 = v_2 - v_1$$

Velocity of approach = Velocity of separation

- (c) **Semi elastic collision:** The material properties of the colliding bodies are not perfectly elastic but partly elastic, so the bodies regain part of its original shape after impact at the point of contact. In this case the momentum is conserved but energy partly conserved.

$$v_2 - v_1 = e(u_1 - u_2)$$

Where: e- coefficient of restitution which value is in between 0 to 1.

Coefficient of Restitution: During the collision the colliding bodies initially under goes a deformation for a small time interval and then recover the deformation in a further small time interval due to elastic property of the body. So the period of collision or time of impact consists of two time intervals i.e. *Period of Deformation* and *Period of Restitution*.

Period of Deformation: It is the time elapse between the instant of initial contact and the instant of maximum deformation of the bodies.

Period of Restitution: It is the time elapse between the instant of maximum deformation condition and the instant of separation of the bodies

Consider two bodies collide and move after collision as shown in Figure below.

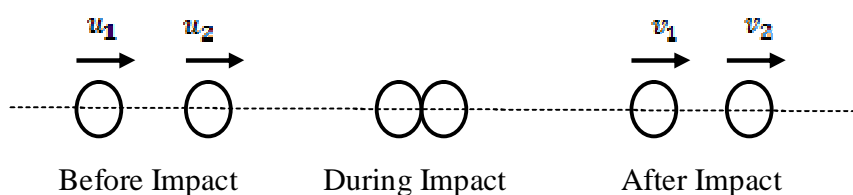

Let m_1 –mass of the first body

m_2 –mass of the second body

u_1 –velocity of the first body before impact

u_2 –velocity of the second body before impact

v_1 –velocity of the first body after impact

v_2 –velocity of the second body after impact

Therefore, Impulse during deformation = $F_D dt$

Where, F_D refers to the force that acts during the period of deformation

The magnitude of F_D is varies from zero at the instant of initial contact to the maximum value at the instant of maximum deformation.

Similarly, Impulse during restitution= $F_R dt$

Where, F_R refer to the force that acts during period of restitution.

The magnitude of F_R is varies from maximum value at the instant of maximum deformation to zero at the instant of just separation of bodies.

At the instant of maximum deformation the colliding bodies will have same velocity. Let the velocity of bodies at the instant of maximum deformation is $U_{D max}$

Applying Impulse-Momentum principle for first body

$$F_D dt = m_1 U_{D max} - m_1 u_1 \quad (1)$$

And $F_R dt = m_1 v_1 - m_1 U_{D max} \quad (2)$

Dividing Equation (2) by (1)

$$\frac{F_R dt}{F_D dt} = \frac{m_1 v_1 - m_1 U_{D max}}{m_1 U_{D max} - m_1 u_1}$$

i.e.

$$\frac{F_R dt}{F_D dt} = \frac{v_1 - U_{D max}}{U_{D max} - u_1}$$

(3)

Similarly for second body,

$$\frac{F_R dt}{F_D dt} = \frac{U_{D \max} - v_2}{u_2 - U_{D \max}}$$

(4)

From Equation (3) and (4)

$$\begin{aligned} \frac{F_R dt}{F_D dt} &= \frac{v_1 - U_{D \max}}{U_{D \max} - u_1} = \frac{U_{D \max} - v_2}{u_2 - U_{D \max}} \\ &= \frac{v_1 - U_{D \max} + U_{D \max} - v_2}{U_{D \max} - u_1 + u_2 - U_{D \max}} \\ &= \frac{v_1 - v_2}{u_2 - u_1} = \frac{v_2 - v_1}{u_1 - u_2} \\ &= \frac{\text{Relative velocity of separation}}{\text{Relative velocity of approach}} \end{aligned}$$

Newton conducted the experiments and observed that when collision of two bodies takes place relative velocity of separation bears a constant ratio to the relative velocity of approach, the relative velocities being measured along the line of impact. This constant ratio is called as the coefficient of restitution and is denoted by “e”. Hence

$$\text{Coefficient of restitution} = e = \frac{v_2 - v_1}{u_1 - u_2}$$

For perfectly elastic bodies the magnitude of relative velocity after impact will be same as that before impact and hence coefficient of restitution will be 1.

For perfectly plastic bodies the velocity of separation is zero as both bodies moving together after impact, so coefficient of restitution is zero.

For semi-elastic collision where some part of energy conserved the value of coefficient of restitution is between 0 to 1.

So the coefficient of restitution always lies between 0 to 1. The value of coefficient of restitution depends not only on the material property, but it also depends on shape and size of the body. Hence the coefficient of restitution is the property of two colliding bodies but not merely of material of colliding bodies.

Solved Examples:

Example 1: Ball having mass 4kg and velocity 8m/s travels to the east. Impulse given at point O, makes it change direction to north with velocity 6m/s. Find the given impulse and change in the momentum.

Solution:

Initial and final momentum vectors of ball are shown in the figure below.

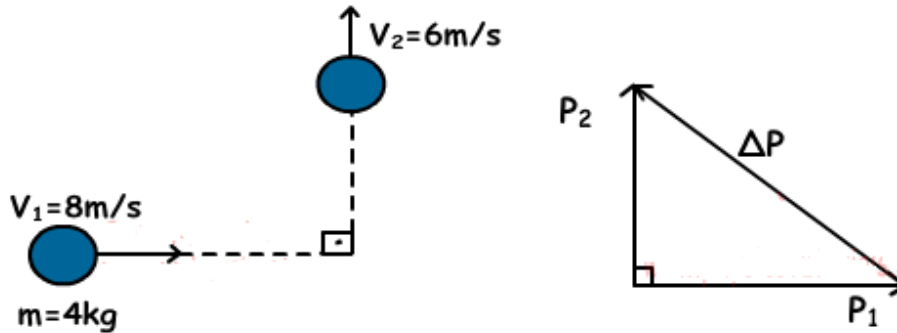

$$P_1 = m \cdot V_1 = 4 \text{ kg} \cdot 8 \text{ m/s} = 32 \text{ kg} \cdot \text{m/s}$$

$$P_2 = m \cdot V_2 = 4 \text{ kg} \cdot 6 \text{ m/s} = 24 \text{ kg} \cdot \text{m/s}$$

$$\Delta P = P_2 + P_1 \text{ (vector addition)}$$

$$\Delta P^2 = P_2^2 + P_1^2 = m^2 (v_2^2 + v_1^2)$$

$$\Delta P^2 = 16 \cdot 100$$

$$\Delta P = 40 \text{ kg} \cdot \text{m/s}$$

Impulse = change in momentum
 $I = \Delta P = 40 \text{ kg} \cdot \text{m/s}$

Example 2: Two blocks are travelling toward each other. The first has a speed of 10 cm/sec and the second a speed of 60 cm/sec. After the collision the second is observed to be travelling with a speed of 20 cm/sec in a direction opposite to its initial velocity. If the weight of the first block is twice that of the second, determine: (a) the velocity of the first block after collision; (b) whether the collision was elastic or inelastic.

Solution: We have a collision problem in 1-dimension. We draw both 'before' and 'after' pictures and select a coordinate system as shown.

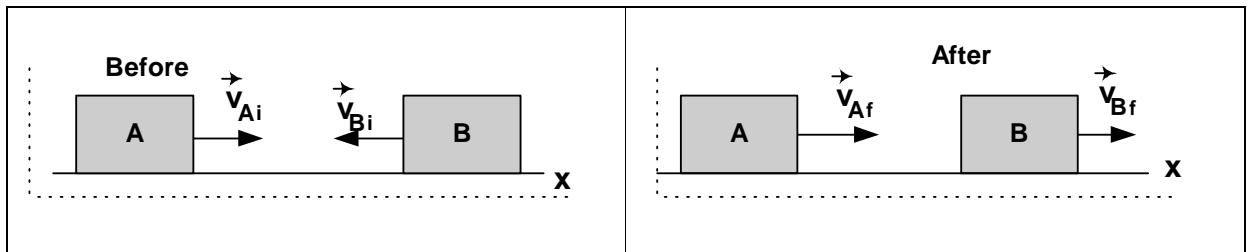

Since the surface is frictionless, and since no work is performed by either mg or the normal, then the net force acting on the system is 0, and we have conservation of linear momentum:

Thus adding the x-components we have: $m_1 v_{1i} - m_2 v_{2i} = m_1 v_{1f} + m_2 v_{2f}$

Since $m_1 = 2 m_2$ we find: $2 v_{1i} - v_{2i} = 2 v_{1f} + v_{2f} \rightarrow (2)(10) - (60) = 2 v_{1f} + 20$

Thus $2 v_{1f} = -60$ and $v_{1f} = -30$ cm/sec ('-' means to left).

The initial KE is given by: $KE_i = (1/2) m_1 (v_{1i})^2 + (1/2) m_2 (v_{2i})^2$. This gives:

$$= (1/2)(2 m_2)(10)^2 + (1/2) m_2 (60)^2 = (1/2)(200 + 3600) m_2 = 1900 m_2$$

The final KE is: $KE_f = (1/2) m_1 (v_{1f})^2 + (1/2) m_2 (v_{2f})^2$. This gives:

$$= (1/2)(2 m_2)(30)^2 + (1/2) m_2 (20)^2 = (1/2)(1800 + 400) m_2 = 1100 m_2$$

Since KE_f is not equal to KE_i , the collision is inelastic.

Example 3: A 0.005 kg bullet going 300 m/sec strikes and is imbedded in a 1.995 kg block which is the bob of a ballistic pendulum. Find the speed at which the block and bullet leave the equilibrium position, and the height which the center of gravity of the bullet-block system reaches above the initial position of the center of gravity.

Solution: A 'ballistic pendulum' is a device which can be used to measure the muzzle velocity of a gun. The bullet is fired horizontally into the block of wood and becomes imbedded in the block. The block is attached to a light rod and can swing like a pendulum. After the collision the 'bob' swings upward and the maximum height it reaches is determined. From this information plus the masses of the bullet and block, one can determine the velocity of the bullet. The critical point to note in this problem is that we have two distinct problems:

Problem 1: A collision problem. Apply Conservation of Linear Momentum and energy relation. Problem 2: A work-energy type problem. Apply conservation of total mechanical energy.

Part 1: We draw before&after pictures, label the velocities, and choose a CS. Conservation of total linear momentum is:

$$m v_{Ai} + M v_{Bi} = (m + M) v_f.$$

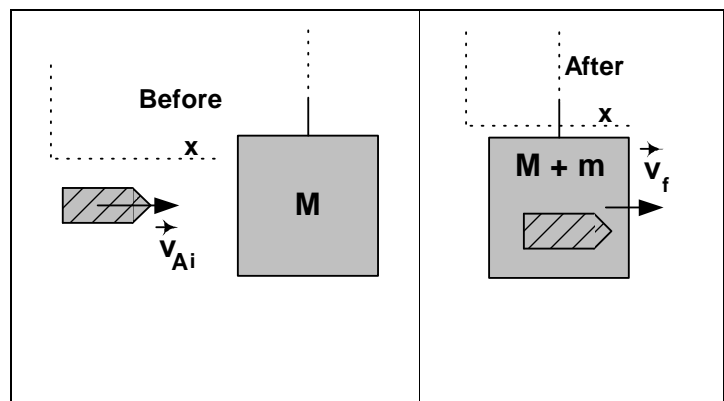

In component form (for x-components) this gives:

$$m v_{Aix} + M v_{Bix} = (m + M) v_{fx}. \quad \text{Since } v_{Bi} = 0, \text{ we have:}$$

$$v_f = (m v_{Ai}) / (m + M) = (.005)(300) / (2.00) = 0.75 \text{ m/sec.}$$

(Note: We were able to 'solve' the collision problem without an 'energy relation' since the collision was a perfectly inelastic collision. That is the two objects had the same final velocity. This condition is equivalent to an 'energy relation', since for such a collision the loss of KE is a maximum possible amount).

Part 2: In the work-energy part of the problem we note that the only force which performs work is gravity. Hence, we have only conservative forces present, and we have conservation of total mechanical energy.

We draw the figure indicating 'initial' and 'final' situations. We may choose the 0 level for gravitational potential energy anywhere we like. Hence, select $U_{\text{ref}} = 0$.

Then: $KE_i + U_i = KE_f + U_f$.

$$(1/2)(m + M) v_f^2 = 0 + (m + M)g h$$

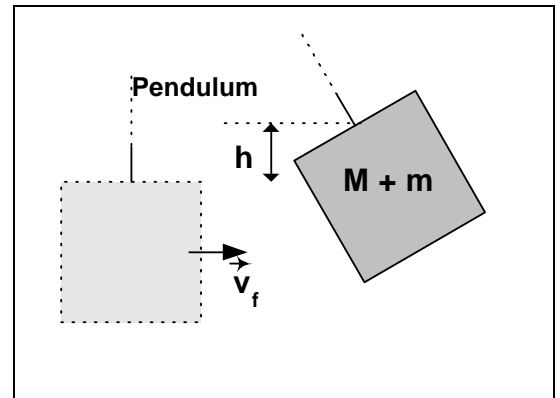

Here v_f is the 'initial' velocity in this part of the problem (0.75 m/sec) and $(m+M)$ is the combined mass of bullet & block.

Thus: $h = v_f^2/2g = (.75)^2/(2)(9.8) = .0287 \text{ m}$ or 2.87 cm.

Note the reversal of this problem. If we know the masses and measure 'h', then from part 2 we can calculate ' v_f ' (the initial velocity of bullet & block in the 2nd part of the problem). This is the same as v_f , the final velocity in the collision problem. Thus using this we can calculate v_{Ai} the 'muzzle' velocity of the bullet.

Example 4: A pile hammer weighing 20 kN drops from a height of 750mm on a pile of 10kN. The pile penetrates 100mm per blow. Assuming that the motion of the pile is resisted by a constant force, find the resistance to penetrate of the ground.

Solution: Initial velocity of hammer= $u=0$

Distance moved= $h= 750\text{mm}=0.75\text{m}$

Acceleration, $g= 9.81\text{m}/\text{sec}^2$

Velocity at the time of strike = $\sqrt{2gh} = \sqrt{2 \times 9.81 \times 0.75} = 3.836\text{m}/\text{sec}$

Applying the principle of conservation of momentum to pie and hammer, we get velocity V of the pile and hammer immediately after the impact,

$$\frac{20}{9.81} \times 3.836 = \frac{20 + 10}{9.81} V$$

$$V = \frac{20}{30} \times 3.836 = 2.557 \text{ m/sec}$$

Applying work energy equation to the motion of the hammer and pile, resistance R of the ground can be obtained,

$$(20 + 10 - R)s = \frac{20 + 10}{2g} (0 - V^2)$$

$$(30 - R)0.1 = \frac{20 + 10}{2 \times 9.81} (-2.557^2)$$

$$R = 130 \text{ kN}$$